

**NETARTS OCEANSIDE SANITARY DISTRICT (NOSD)  
Public Works Design Standards**

---

**Standard Detail Drawings & Sample Test Report Forms**  
**Appendix A**

---

Note:

- 1) Per PWDS 1.11.b.12, the applicable NOSD standard details shall be included on construction drawings submitted for NOSD review and approval. See also PWDS 1.3.a.3 for detail sheet stamping requirements where engineered drawings are required.
- 2) Per PWDS 1.2.b, the NOSD standard details are intended to assist but not to substitute for competent work by design professionals where applicable. As noted in the PWDS, the NOSD standard details illustrate the minimum requirements and materials required by the NOSD for the construction of certain standard system components, and are thus not considered to be final documents until incorporated into a design approved by the NOSD,



**NETARTS OCEANSIDE SANITARY DISTRICT (NOSD)  
PUBLIC WORKS DESIGN STANDARDS**

**TABLE OF CONTENTS, NOSD STANDARD DETAILS**

**• A1 - General Requirements & Trenches** Latest Revision

101	Typical Utility Locations (Curbed Streets) .....	4/24
102	Typical Utility Locations (Turnpike Streets) .....	4/24
226	6-inch Bollard (Guard Post) .....	2/25
227	8-inch Bollard (Guard Post) .....	2/25
228	30" Tall Collapsible Padlockable Bollard .....	2/24
301	Trench Backfill, Bedding and Pipe Zone .....	4/26
302	Minor or Private Street & AC Driveway Cut Surface Restoration .....	1/26
302A	AC Street Cut Surface Restoration w/Bench Grind .....	1/26
302D	ODOT Trench Crossing, Trench Backfill & Surface Restoration .....	2/24
303	Gravel Surface Restoration .....	12/15
304	Native Surface Restoration .....	12/15
308	Bore Casing, Carrier Pipe & Casing Spacer Detail .....	3/24

**• A4 - Sanitary Sewers** Latest Revision

▶	For trench backfill and surface restoration, see Details 301 - 304	
▶	For bore casing detail, see Detail 308	
401	Standard Manhole for 21" Pipe and Smaller .....	9/25
401A	Connection at New MHs & Other Transition Points (Sanitary Sewer).....	9/24
402	Flattop Manhole for 21" Pipe and Smaller .....	10/25
404	Inside Drop Connection for Sanitary Sewer Manhole.....	3/26
405	Manhole Frame and Cover (Standard and Suburban) .....	9/24
405A	Adjustable Manhole Frame (Rim-Riser) .....	9/24
406	Lockdown Manhole Frame and Cover .....	12/15
407	Manhole Rim Adjustment Details .....	10/25
411	Mainline Cleanout .....	5/24
415	Sewer Service Lateral .....	3/26
415A	Lateral Cut-in Connection at Existing SS or SD Mains Too Small for Detail 419.....	9/25
416	Standard Service Lateral Cleanout .....	2/24
419A	Fatboy Inserta-Tee Connection to Existing Sewer .....	10/25
501	Gate Valve and Valve Box Detail .....	7/24
505	Tapping Tee & Valve .....	9/18
510	Horizontal Thrust Blocking .....	10/24
511	Straddle Block for 12" & Smaller Pipe .....	12/21
529	Galvanized Pipe Supports w/Galvanized Ext Pipe.....	1/18

**Test Reports**

- ▶ Manhole Vacuum Test Report
- ▶ Sanitary Sewer Air Test Report
- ▶ Sanitary Sewer Mandrel Test Report
- ▶ Sanitary Sewer Pipeline TV Inspection Report

• **A6 - Erosion Control**

610	Temporary Construction Entrance .....	5/13
611	Sediment Barriers .....	4/14
612	Straw Wattle Sediment Barrier .....	6/15
613	Inlet Sediment Control .....	4/14
614	Ditch & Swale Protection .....	4/14
615	Silt Sack Inlet Detail .....	10/06
616	Temporary Concrete Washout Area (CWA).....	11/18
617	Stockpile Cover Detail.....	1/19

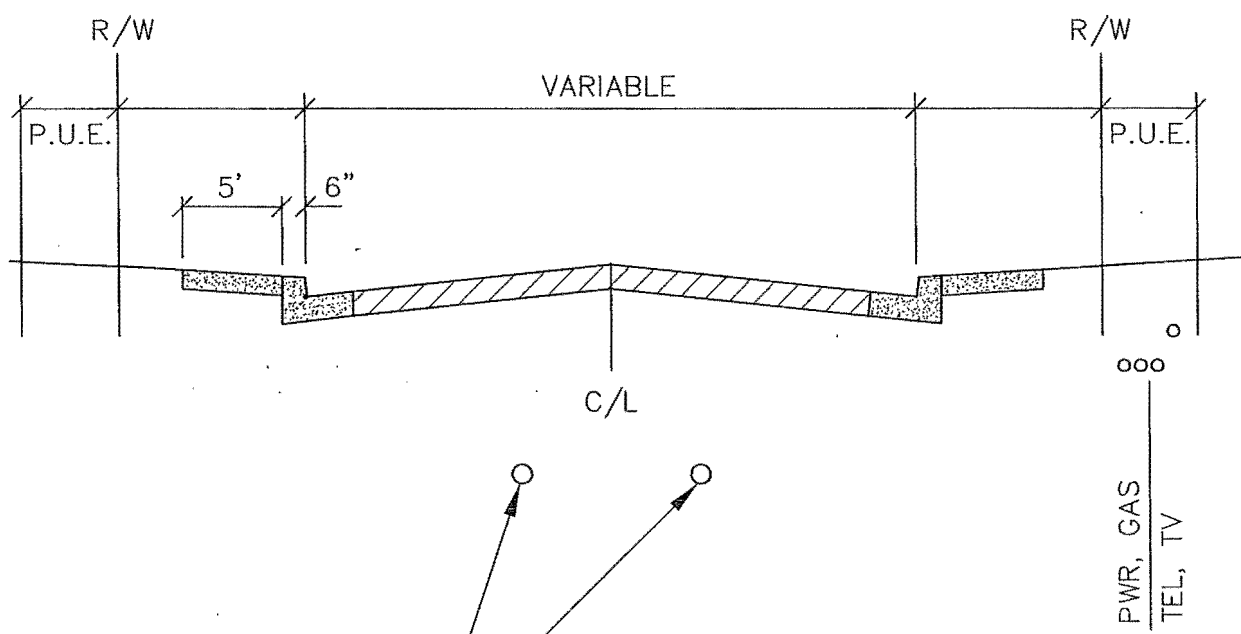

S.S. - 5' FROM C/L ON  
 LOW SIDE OF STREET  
 UNLESS OTHERWISE  
 REQUIRED BY NOSD.  
 SEE NOTES 1 & 2

## CURBED STREETS

NTS

NOTES:

1. 6' MIN. COVER REQUIRED ON SANITARY SEWER MAINS UNLESS APPROVED BY DISTRICT SUPERINTENDENT.
2. LATERALS AND P/L CLEANOUTS SHALL BE INSTALLED DURING CONSTRUCTION OF SANITARY SEWER MAINS.
3. MAINTAIN MIN. 5' HORIZ. SEPARATION BETWEEN PUBLIC UTILITIES & PARALLEL PRIVATE UTILITIES. OTHER VERT. AND HORIZ. SEPARATION DISTANCES ARE CONTROLLED BY DEQ, OHD, AND OTHER PUBLIC/PRIVATE UTILITY COMPANIES.

LAST REVISION DATE: APR 2024	<small>COPYRIGHT 1999 WESTECH ENGINEERING, INC.</small>
<b>TYP. UTILITY LOCATIONS (CURBED STREETS)</b>	
(NTS)	
NOSD, OR	DETAIL NO. <b>101</b>

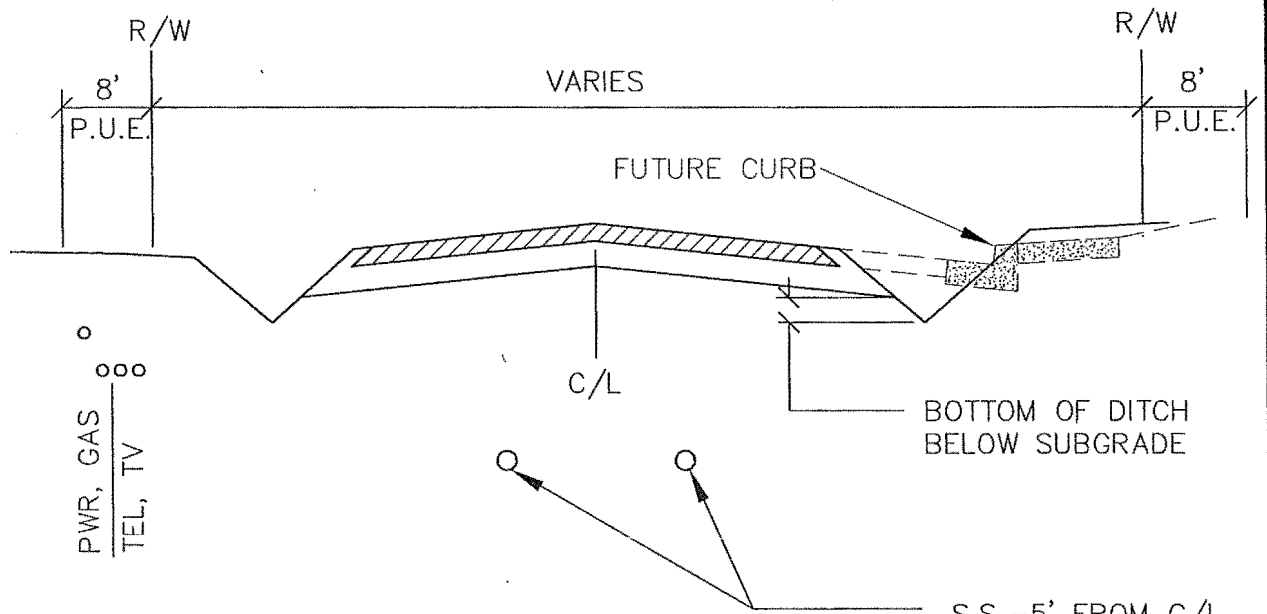

NOTE:

UTILITIES FOR TURNPIKE STREETS OR 3/4 STREET IMPROVEMENTS SHALL BE LOCATED TO ALLOW FUTURE CONSTRUCTION OF CURBED STREETS WITHOUT RELOCATING UTILITIES. SEE DETAIL 101.

S.S. - 5' FROM C/L ON LOW SIDE OF STREET UNLESS OTHERWISE REQUIRED BY NOSD

## TURNPIKE STREETS

NTS

NOTES:

1. 6' MIN. COVER REQUIRED ON SANITARY SEWER MAINS UNLESS APPROVED BY DISTRICT SUPERINTENDENT.
2. LATERALS AND P/L CLEANOUTS SHALL BE INSTALLED DURING CONSTRUCTION OF SANITARY SEWER MAINS.
3. MAINTAIN MIN. 5' HORIZ. SEPARATION BETWEEN PUBLIC UTILITIES & PARALLEL PRIVATE UTILITIES. OTHER VERT. AND HORIZ. SEPARATION DISTANCES ARE CONTROLLED BY DEQ, OHD, AND OTHER PUBLIC/PRIVATE UTILITY COMPANIES.

LAST REVISION DATE: APR 2024	COPYRIGHT 1996 WESTECH ENGINEERING, INC.
<b>TYP. UTILITY LOCATIONS (TURNPIKE STREETS)</b>	
(NTS)	
NOSD, OR	DETAIL NO. <b>102-</b>

CONTRACTOR SHALL COORDINATE WITH NOSD FOR BOLLARD COLOR PRIOR TO ORDERING SLEEVE.

WHERE PAINTED BOLLARDS ARE NOTED ON OTHER DETAILS, OMIT THE HDPE SLEEVE.

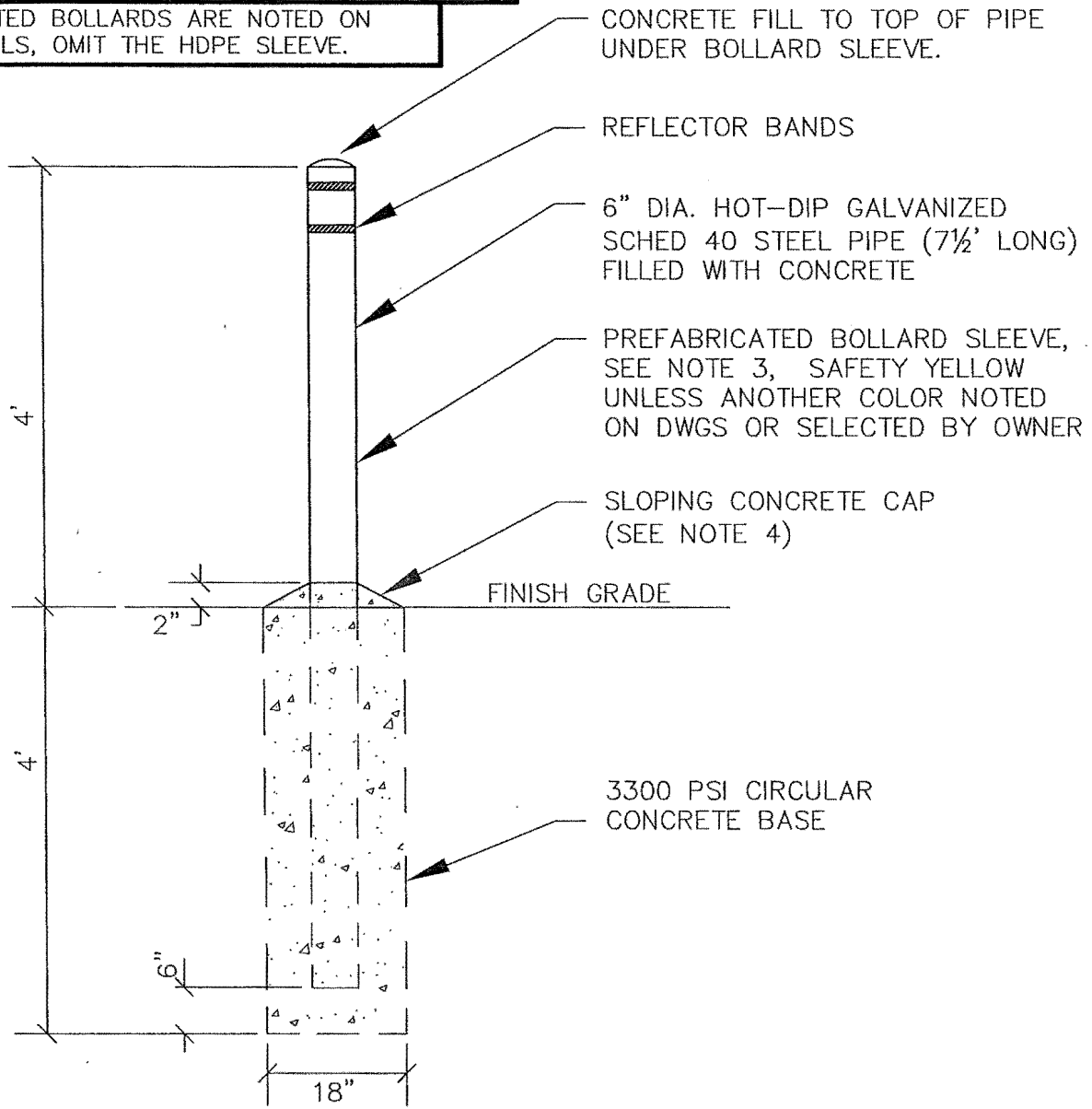

**NOTES:**

1. CORE DRILLING. IF BOLLARDS ARE PLACED IN AC PAVEMENT OR CONCRETE AREAS, HOLES FOR THE CONCRETE ANCHOR BASE SHALL BE CORE DRILLED TO DIMENSIONS SHOWN.
2. FOUNDATION HOLE INSPECTION. CONTRACTOR SHALL COORDINATE WITH NOSD FOR INSPECTION OF BASE HOLES (DIAMETER & DEPTH) PRIOR TO CONCRETE PLACEMENT.
3. PREFABRICATED BOLLARD SLEEVES SHALL BE CLOSED TOP HDPE SLEEVES (1/8-INCH WALL THICKNESS) WITH ULTRAVIOLET INHIBITORS TO RETARD CRACKING AND FADING. SLEEVES SHALL BE SAFETY YELLOW AND PROVIDED WITH TWO RECESSED RED REFLECTORIZED BANDS FABRICATED INTO THE UPPER END (ENCORE POSTGUARD OR EQUAL). SLEEVES SHALL BE PROVIDED WITH FOAM STRIPS AS REQUIRED TO FIT SNUGLY OVER THE STEEL POST CORE, AND SLEEVES SHALL EXTEND TO COVER THE FULL HEIGHT OF THE EXPOSED CORE POST.
4. CONCRETE FOUNDATION SHALL BE CROWNED ABOVE FINISH GRADE AS SHOWN (TO DIRECT DRAINAGE AWAY FROM POST).
5. INSTALL HDPE BOLLARD SLEEVE AFTER GRADING, PAVING OR SURFACING IS COMPLETE TO AVOID DAMAGING SLEEVE.
6. ALL CONCRETE SHALL BE 3300 PSI @ 28 DAYS, MAX 5" SLUMP, 4.5% AIR (±1.5%).

LAST REVISION DATE: FEB 2025	COPYRIGHT 1986 WESTECH ENGINEERING, INC.
<b>6-INCH BOLLARD (GUARD POST)</b>	
(NTS)	
NOSD, OR	DETAIL NO. 226

CONTRACTOR SHALL COORDINATE WITH NOSD FOR BOLLARD COLOR PRIOR TO ORDERING SLEEVE.

WHERE PAINTED BOLLARDS ARE NOTED ON OTHER DETAILS, OMIT THE HDPE SLEEVE.

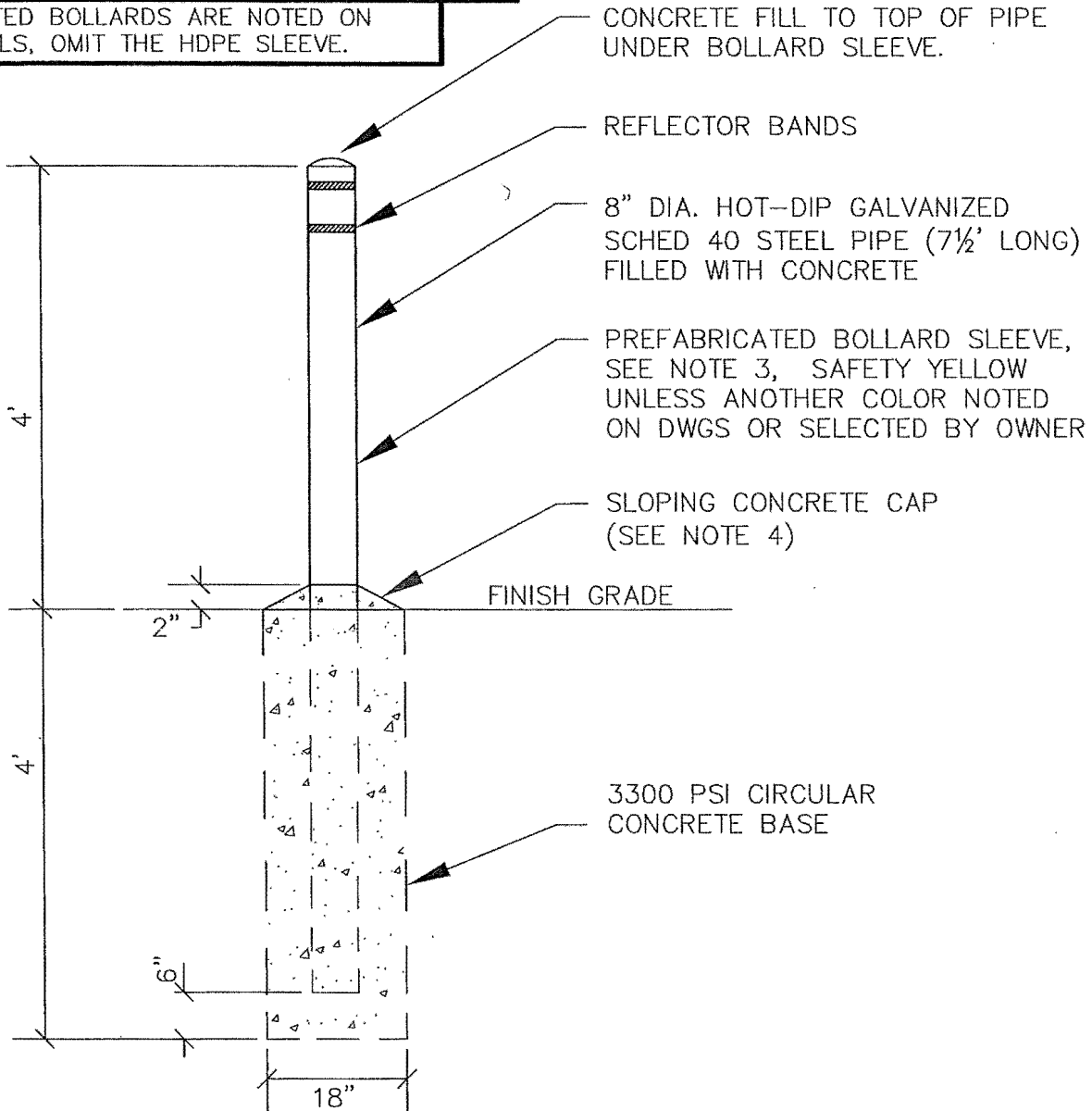

**NOTES:**

1. CORE DRILLING. IF BOLLARDS ARE PLACED IN AC PAVEMENT OR CONCRETE AREAS, HOLES FOR THE CONCRETE ANCHOR BASE SHALL BE CORE DRILLED TO DIMENSIONS SHOWN.
2. FOUNDATION HOLE INSPECTION. CONTRACTOR SHALL COORDINATE WITH NOSD FOR INSPECTION OF BASE HOLES (DIAMETER & DEPTH) PRIOR TO CONCRETE PLACEMENT.
3. PREFABRICATED BOLLARD SLEEVES SHALL BE CLOSED TOP HDPE SLEEVES (1/8-INCH WALL THICKNESS) WITH ULTRAVIOLET INHIBITORS TO RETARD CRACKING AND FADING. SLEEVES SHALL BE SAFETY YELLOW AND PROVIDED WITH TWO RECESSED RED REFLECTORIZED BANDS FABRICATED INTO THE UPPER END (ENCORE POSTGUARD OR EQUAL). SLEEVES SHALL BE PROVIDED WITH FOAM STRIPS AS REQUIRED TO FIT SNUGLY OVER THE STEEL POST CORE, AND SLEEVES SHALL EXTEND TO COVER THE FULL HEIGHT OF THE EXPOSED CORE POST.
4. CONCRETE FOUNDATION SHALL BE CROWNED ABOVE FINISH GRADE AS SHOWN (TO DIRECT DRAINAGE AWAY FROM POST).
5. INSTALL HDPE BOLLARD SLEEVE AFTER GRADING, PAVING OR SURFACING IS COMPLETE TO AVOID DAMAGING SLEEVE.
6. ALL CONCRETE SHALL BE 3300 PSI @ 28 DAYS, MAX 5" SLUMP, 4.5% AIR (±1.5%).
7. 8" BOLLARD TYPICALLY ONLY REQUIRED FOR LARGE COMMERCIAL/INDUSTRIAL TRUCK TRAFFIC.

LAST REVISION DATE: FEB 2025	COPYRIGHT 1995 WESTECH ENGINEERING, INC.
<b>8-INCH BOLLARD (GUARD POST)</b>	
(NTS)	
NOSD, OR	DETAIL NO. 227

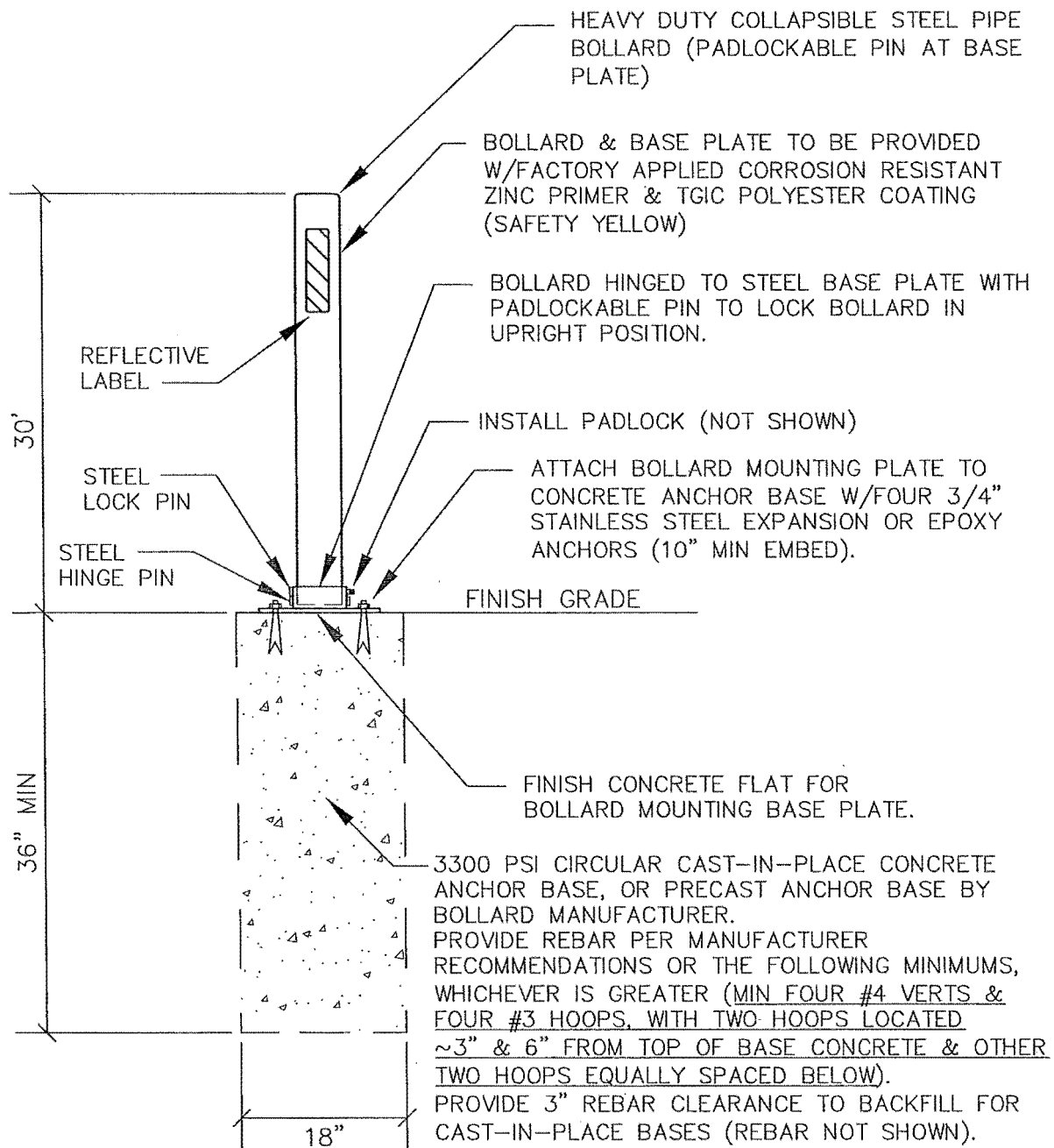

**NOTES:**

1. BOLLARD BASE MOUNTING PLATE AND BOLLARD SHALL BE 4-INCH MAXIMUM HEIGHT WHEN IN COLLAPSED/DOWN POSITION.
2. UNLESS OTHERWISE SPECIFIED, PROVIDE WEATHER RESISTANT PADLOCK KEYED TO SPECIFIED PATTERN (CONTRACTOR TO COORDINATE WITH FIRE CODE OFFICIAL FOR KNOX AS APPLICABLE).
3. COLLAPSIBLE BOLLARD ASSEMBLY SHALL BE TRAFFIC-GUARD MODEL LPHDHB OR APPROVED EQUAL.
4. CONTRACTOR SHALL VERIFY BOLLARD HINGE LOCATION (IE. COLLAPSE DIRECTION) WITH NOSD, OWNER AND/OR FIRE CODE OFFICIAL PRIOR TO INSTALLATION, AS APPLICABLE.
5. IF BOLLARDS ARE PLACED IN AC PAVEMENT OR CONCRETE AREAS, HOLES FOR THE CONCRETE ANCHOR BASE SHALL BE CORE DRILLED TO DIMENSIONS SHOWN.
6. CONTRACTOR SHALL COORDINATE WITH NOSD FOR INSPECTION OF BASE HOLES (DIAMETER & DEPTH) PRIOR TO CONCRETE PLACEMENT.
7. ALL CONCRETE SHALL BE 3300 PSI @ 28 DAYS, MAX 5" SLUMP, 4.5% AIR (±1.5%).

LAST REVISION DATE:	FEB 2024
<b>30" TALL COLLAPSIBLE PADLOCKABLE BOLLARD</b>	
(NTS)	
NOSD, OR	DETAIL NO. 228

TRENCH COMPACTION: CLASS 1 GRANULAR BACKFILL - 92% OPTIMUM PER AASHTO T-180 (MODIFIED PROCTOR)  
 CLASS 3 NATIVE BACKFILL - 85% OPTIMUM PER AASHTO T-180

**SURFACE RESTORATION CLASS**

(SEE DTLS 302-304 FOR REQ'MTS)

95% COMPACTION REQ'D W/IN STREET BASEROCK THICKNESS (UNDER EXISTING STREETS) PER AASHTO T-180

12" MIN.  
18" MAX.  
TO TAPE

**6-INCH WIDE UNDERGROUND WARNING TAPE**

(COLOR & WORDS AS REQ'D FOR WATER, SEWER, STORM, ETC.)

**CLASS 1 BACKFILL:**  
3/4"-0" GRANULAR BACKFILL  
(92% COMPACTION, SEE ABOVE)

**CLASS 3 BACKFILL:**  
CLEAN NATIVE BACKFILL ABOVE PIPE ZONE  
(85% COMPACTION, SEE ABOVE)

(% TRENCH COMPACTION PER NOTES ABOVE, SEE NOTE 2)

COMPACTED BACKFILL

12" MIN. ABOVE OUTSIDE OF PIPE BELL (TYPICAL ALL PIPE TYPES)

TRACER WIRE ALONG ALL PIPE & LATERALS (TAPE TO PIPE BELOW CROWN, AT 5' MAX INTERVALS, 10:30 OR 1:30 POSITION) GREEN=SEWER

6" MIN BEDDING BELOW PIPE (TYPICAL ALL PIPE TYPES, ALL LOCATIONS)

"A" NOM. PIPE DIAMETER	"B" MIN/MAX CLEARANCE
≤10	10"/18"
12"-16"	12"/18"
18"-21"	16"/24"
24"-30"	18"/30"
>30"	24"/36"

(SEE NOTE 5)

**TRENCH FOUNDATION STABILIZATION:** IF TRENCHES ARE OVER-EXCAVATED FOR ANY REASON, OVER-EXCAVATION SHALL BE FILLED TO THE DESIGN TRENCH SUBGRADE (IE. TO THE BOTTOM OF THE 6" THICK BEDDING) WITH COMPACTED, WELL-GRADED GRANULAR BACKFILL AS SPECIFIED (IE. THE USE OF OPEN GRADED ROCK IS PROHIBITED UNLESS IT IS COMPLETELY ENCAPSULATED IN GEOTEXTILE FABRIC & APPROVED BY AHJ).

STABLE SUBGRADE, OR TRENCH FOUNDATION STABILIZATION AS REQUIRED

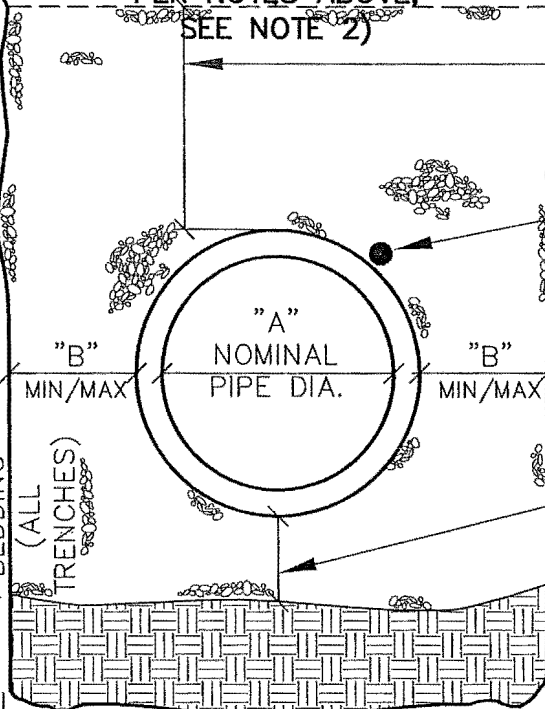

24" MIN. (SEE TABLE)

**NOTES:**

- CLASS 1 GRANULAR BACKFILL REQUIRED UNDER ALL EXISTING OR FUTURE IMPROVED AREAS, INCLUDING STREETS, SHOULDERS, PARKING, SIDEWALKS, ETC.
- SUBMIT WRITTEN BACKFILL COMPACTION TEST RESULTS PRIOR TO INSTALLING AC PAVEMENT OR CONCRETE SURFACE RESTORATION.
- WHERE NEW PIPING IS IN SAME ALIGNMENT AS EXISTING PIPING, GRANULAR PIPE EMBEDMENT SHALL EXTEND TO A MIN. OF 6" BELOW THE NEW PIPING OR 6" BELOW EXISTING PIPING, WHICHEVER IS DEEPER.
- SHORING NOTE. PIPE ZONE:** FOR FLEXIBLE PIPE, BOTTOM OF TRENCH SHORING SHALL BE ABOVE PIPE SPRINGLINE PRIOR TO COMPACTING BACKFILL BELOW THE PIPE SPRINGLINE AND UNDER THE PIPE HAUNCHES (TO AVOID LOSS OF PIPE SIDE SUPPORT).
- MINIMUM CLEARANCES SHOWN ("B") ASSUMES STANDARD 6" WALL TRENCH BOXES SET ON TRENCH BOTTOM, AND REPRESENTS WIDTH REQUIRED TO CONSOLIDATE GRANULAR MATERIAL UNDER PIPE HAUNCHES (TO AVOID LOSS OF SIDE SUPPORT WHEN TRENCH BOX IS MOVED OR PULLED FORWARD). TRENCH WIDTH REDUCTION REQUIRES PRIOR APPROVAL BASED ON ACTUAL TRENCH SHORING PROPOSED.

LAST REVISION DATE:

APR 2026

**TRENCH BACKFILL, BEDDING, AND PIPE ZONE**

(NTS)

NOSD, OR

DETAIL NO.

301

PLACE 4" MIN. THICKNESS, 1/2" DENSE GRADED MIX (LEVEL 2 JMF) IN TWO EQUAL LIFTS, OR THICKNESS OF REMOVED PAVEMENT (WHICHEVER IS GREATER), COMPACT TO 91% OPTIMUM DENSITY PER RICE STANDARD METHOD.

SEAL SURFACE OVER JOINT WITH TACK MATERIAL AND SAND (AC PATCH ONLY)

MIN. TRENCH PATCH WIDTH  
ROLLER WIDTH PLUS 2"

EXISTING PAVEMENT

6"  
MIN.

TACK COAT CUT EDGES

6"  
MIN.

EXISTING PAVEMENT

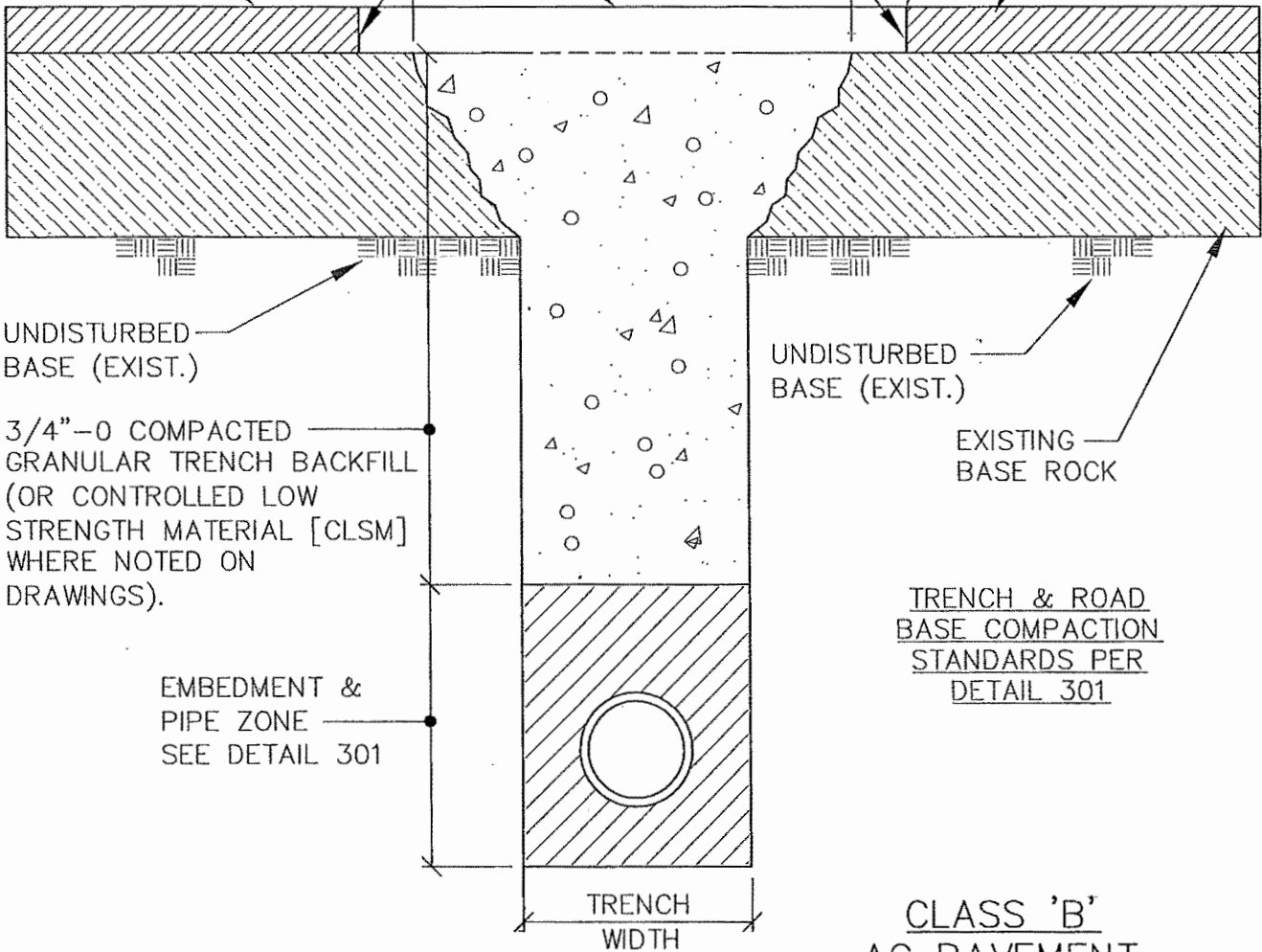

UNDISTURBED  
BASE (EXIST.)

3/4"-0 COMPACTED  
GRANULAR TRENCH BACKFILL  
(OR CONTROLLED LOW  
STRENGTH MATERIAL [CLSM]  
WHERE NOTED ON  
DRAWINGS).

EMBEDMENT &  
PIPE ZONE  
SEE DETAIL 301

UNDISTURBED  
BASE (EXIST.)

EXISTING  
BASE ROCK

TRENCH & ROAD  
BASE COMPACTION  
STANDARDS PER  
DETAIL 301

TRENCH  
WIDTH

CLASS 'B'  
AC PAVEMENT  
RESTORATION

NOTES:

1. SUBMIT WRITTEN BACKFILL COMPACTION TEST RESULTS PRIOR TO INSTALLING AC PAVEMENT OR CONCRETE SURFACE RESTORATION.
2. ALL EXISTING AC OR PCC PAVEMENT SHALL BE SAWCUT TO PROVIDE A CLEAN EDGE PRIOR TO REPAVING.
3. PCC CONCRETE PAVEMENT SHALL BE REPLACED TO A MINIMUM THICKNESS OF 6" OR TO THE THICKNESS OF REMOVED CONCRETE, WHICHEVER IS GREATER (CONCRETE SHALL BE 3300 PSI MIN @ 28 DAYS, MAX 5" SLUMP, 4.5% AIR (±1.5%).).
4. FOR PAVED DRIVEWAYS (EXCEPT COMMERCIAL OR INDUSTRIAL) WITH LESS THAN 4" EXISTING AC PAVEMENT THICKNESS MAY BE REDUCED TO 3" AC IN 2 LIFTS, AND OVERCUT MAY BE REDUCED TO 3" EACH SIDE.

LAST REVISION DATE:	
JAN 2026	
<b>MINOR OR PRIVATE STREET AND AC DRIVEWAY CUT SURFACE RESTORATION</b>	
(NTS)	
NOSD, OR	DETAIL NO. 302

PLACE 4" MIN. THICKNESS, 1/2" DENSE GRADED MIX (LEVEL 2 JMF) IN TWO EQUAL LIFTS, OR THICKNESS OF REMOVED PAVEMENT (WHICHEVER IS GREATER), COMPACT TO 91% OPTIMUM DENSITY PER RICE STANDARD METHOD.

18" MIN. WIDTH PRE-TACKED PAVING FABRIC (MIRAFI MTK, PETROTAC OR EQUAL), SIDE & END JOINTS.

SEAL SURFACE OVER JOINT WITH TACK MATERIAL AND SAND.

GRIND 24" BENCH INTO EXTG AC PAVEMENT. SEE NOTE 2 BELOW (18" MIN. WIDTH AFTER SAWCUT).

MIN. TRENCH PATCH WIDTH  
ROLLER WIDTH PLUS 2"

6" MIN.

TACK COAT CUT EDGES & GRIND AREAS

6" MIN.

EXISTING PAVEMENT

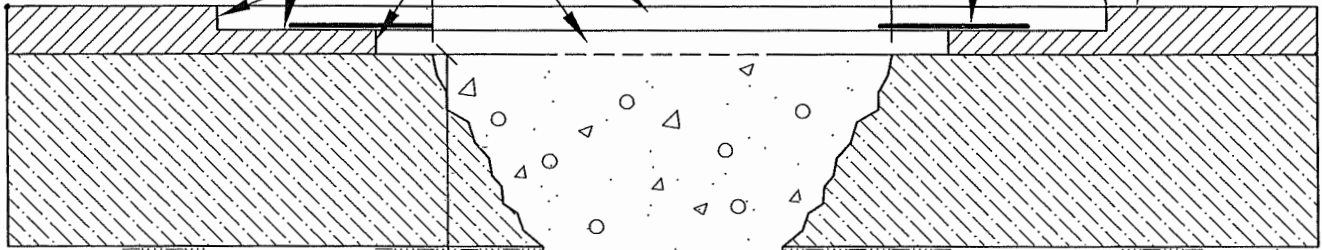

UNDISTURBED BASE (EXIST.)

3/4"-0 GRANULAR BACKFILL (OR 'CONTROLLED LOW STRENGTH MATERIAL [CLSM] WHERE NOTED ON DRAWINGS) FROM 12" OVER PIPE TO BOTTOM OF AC (BACKFILL TYPE AS INDICATED ON DWGS). FOR CSLM, STEEL PLATE FOR 24 HOURS PRIOR TO PLACING COLD MIX OR AC SURFACE RESTORATION.

UNDISTURBED BASE (EXIST.)

EXISTING BASE ROCK

TRENCH & ROAD  
BASE COMPACTION  
STANDARDS PER  
DETAIL 301

EMBEDMENT & PIPE ZONE  
SEE DETAIL 301

**SURFACE MAINT UNTIL FINAL AC.**  
TRENCHES IN PAVED AREAS SHALL BE STEEL PLATED OR COLD PATCHED (AND MAINTAINED) AT THE END OF EACH WORKDAY. FINAL HOT PATCH REPAVING TO OCCUR W/IN 14 DAYS OF EXCAVATION UNLESS OTHERWISE APPROVED PER PWDS G.11.b. REMOVE ALL COLD PATCH PRIOR TO FINAL PAVING.

TRENCH WIDTH

**NOTES:**

1. SUBMIT WRITTEN BACKFILL COMPACTION TEST RESULTS PRIOR TO INSTALLING AC PAVEMENT TRENCH RESTORATION.
2. FOLLOWING BACKFILL COMPACTION & TESTING OR CSLM INSTALLATION, GRIND 24" WIDE BENCH IN EXISTING AC ON BOTH SIDES & TRENCH ENDS, 2" DEEP OR HALF THE DEPTH OF EXISTING AC (3" MAX).
3. AFTER GRINDING, SAWCUT ALONG TRENCH SIDES AS REQUIRED TO PROVIDE A CLEAN EDGE PRIOR TO REPAVING, 6" BACK FROM TRENCH EDGE.
4. BASE LIFT(S). TACK COAT EDGES, INSTALL/COMPACT BASE LIFTS (3" MAX LIFT) TO LEVEL OF BENCH GRIND.
5. FINISH LIFT. INSTALL JOINT SEAL FABRIC, TACK COAT GRIND SURFACES & EDGES, & INSTALL TOP LIFT OF AC. SAND SEAL ALL JOINTS (REMOVE EXCESS SAND AFTER CURE).

**CLASS 'A'  
AC PAVEMENT  
RESTORATION**

LAST REVISION DATE: JAN 2026	
<b>AC STREET CUT SURFACE RESTORATION W/BENCH GRIND (NTS)</b>	
NOSD, OR	DETAIL NO. 302A

INSTALL TWO 2" LIFTS OF LEVEL 3 1/2-INCH ACP PER ODOT SPECS, **OR MATCH EXISTING PAVEMENT THICKNESS**, WHICHEVER IS GREATER. (3" MAX LIFT THICKNESS).

PLACE (2) 2" LIFTS, LEVEL 3 1/2-INCH ACP PER ODOT SPECS

GRIND THIS AREA 4" DEEP FOR 10 FEET MIN EACH WAY FROM TRENCH EDGE UNLESS OTHERWISE APPROVED OR REQUIRED BY ODOT.

TACK COAT PRIOR TO PAVING & SAND SEAL JOINTS AFTER PAVING.

MIN. TRENCH PATCH WIDTH  
TRENCH WIDTH + 2\*GRIND WIDTH

EXISTING PAVEMENT

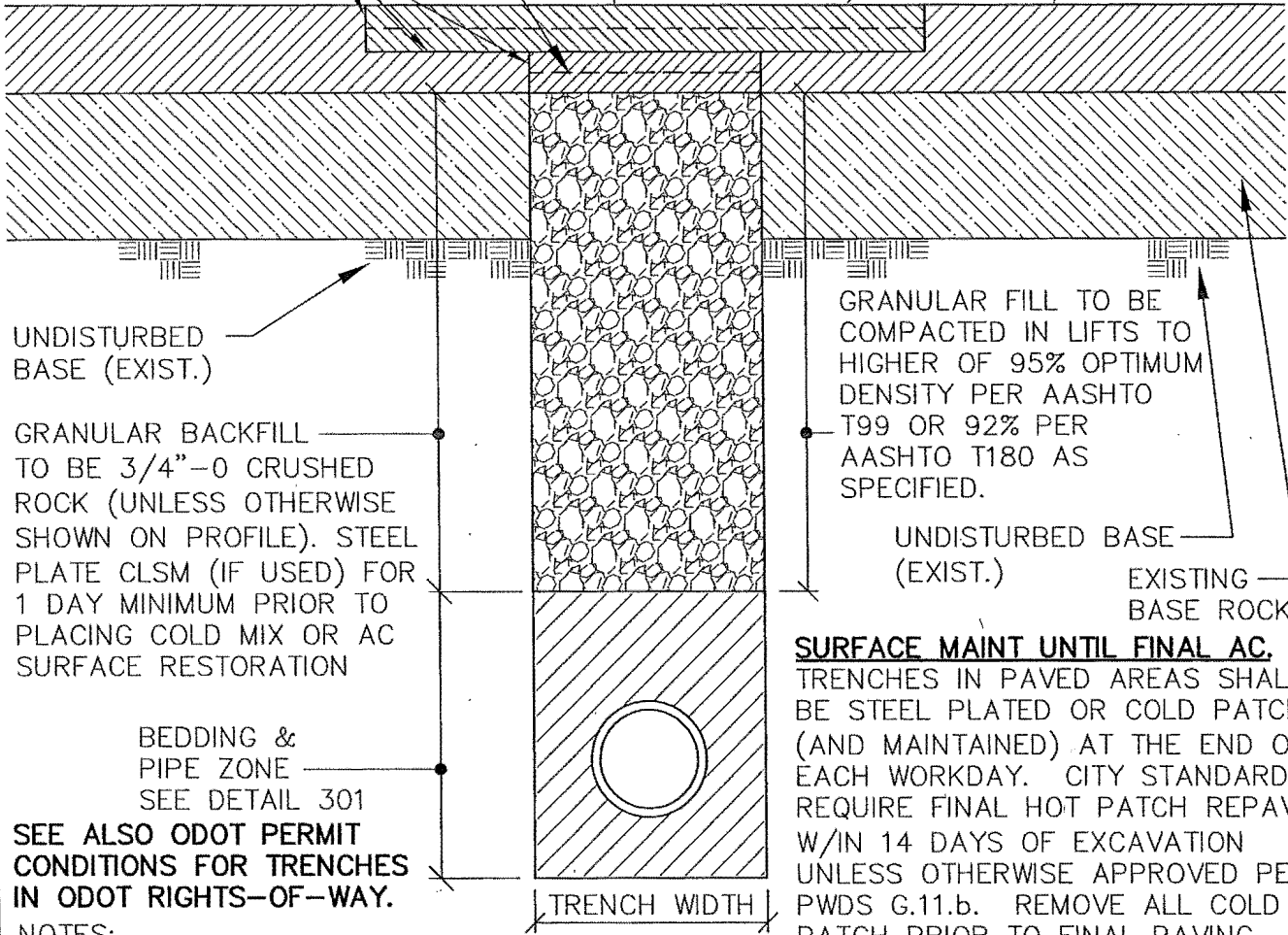

UNDISTURBED BASE (EXIST.)

GRANULAR BACKFILL TO BE 3/4"-0 CRUSHED ROCK (UNLESS OTHERWISE SHOWN ON PROFILE). STEEL PLATE CLSM (IF USED) FOR 1 DAY MINIMUM PRIOR TO PLACING COLD MIX OR AC SURFACE RESTORATION

BEDDING & PIPE ZONE SEE DETAIL 301

SEE ALSO ODOT PERMIT CONDITIONS FOR TRENCHES IN ODOT RIGHTS-OF-WAY.

NOTES:

GRANULAR FILL TO BE COMPACTED IN LIFTS TO HIGHER OF 95% OPTIMUM DENSITY PER AASHTO T99 OR 92% PER AASHTO T180 AS SPECIFIED.

UNDISTURBED BASE (EXIST.)

EXISTING BASE ROCK

**SURFACE MAINT UNTIL FINAL AC.** TRENCHES IN PAVED AREAS SHALL BE STEEL PLATED OR COLD PATCHED (AND MAINTAINED) AT THE END OF EACH WORKDAY. CITY STANDARDS REQUIRE FINAL HOT PATCH REPAVING W/IN 14 DAYS OF EXCAVATION UNLESS OTHERWISE APPROVED PER PWDS G.11.b. REMOVE ALL COLD PATCH PRIOR TO FINAL PAVING.

1. SUBMIT WRITTEN BACKFILL COMPACTION TEST RESULTS PRIOR TO AC PAVEMENT INSTALLATION.
2. COMPACT ALL ACP LIFTS TO 91% OPTIMUM DENSITY PER RICE STANDARD METHOD.
3. ASPHALT EMULSION TACK COAT SHALL BE USED TO SEAL THE ACP TO THE EDGES OF THE EXISTING AC PAVEMENT. ALL AC PAVEMENT CUTS SHALL BE VERTICAL, CLEAN & ASPHALT SAND SEALED ALONG ALL EDGES AFTER INSTALLATION.
4. ALL PAVEMENT CUT AREAS SHALL BE COLD PATCHED OR PLATED AT THE END OF EACH WORK SHIFT, & THE PLATES OR PATCH MAINTAINED UNTIL FULL PAVEMENT RESTORATION IS MADE WITH ACP. COLD PATCH (IF USED) SHALL BE REPLACED WITH HOT MIX ACP WITHIN TIMEFRAME DIRECTED IN WRITING BY THE ODOT DISTRICT MANAGER OR MANAGER'S REPRESENTATIVE.
5. ACP SHALL BE A COMMERCIALY PRODUCED PLANT MIXTURE CONFORMING TO ODOT STANDARDS, OSSC 00744 (OLD "B" OR "C" DESIGNATION ON CITY DETAILS REFERS TO AGGREGATE SIZE ONLY).
6. 48" MINIMUM COVER IS REQUIRED FOR ALL GAS, ELECTRIC, TELEPHONE, FIBER OPTIC AND OTHER POTENTIALLY DANGEROUS/HIGH IMPACT UTILITY FACILITIES, ALL OTHER FACILITIES REQUIRE 36" MINIMUM COVER DEPTH.

LAST REVISION DATE: FEB 2024	
<b>ODOT TRENCH CROSSING, TRENCH BACKFILL &amp; SURFACE RESTORATION</b> (NTS)	
NOSD, OR	DETAIL NO. <b>302D</b>

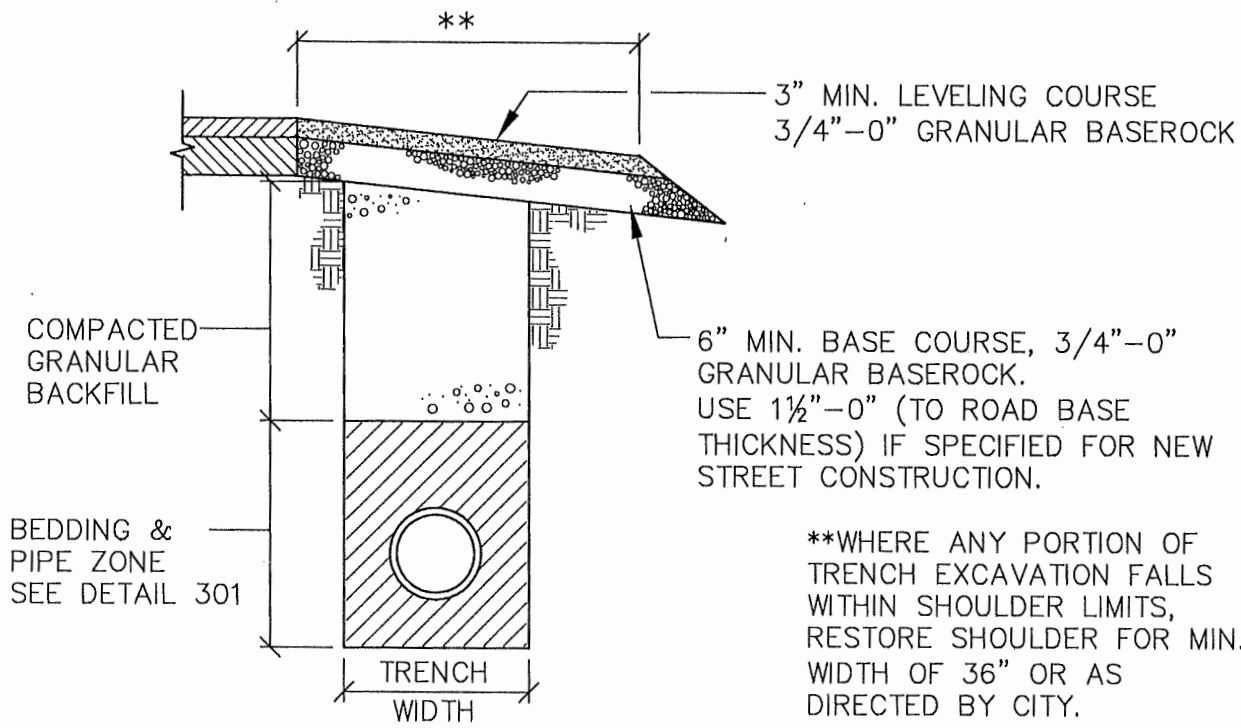

3" MIN. LEVELING COURSE  
3/4"-0" GRANULAR BASEROCK

6" MIN. BASE COURSE, 3/4"-0"  
GRANULAR BASEROCK.  
USE 1 1/2"-0" (TO ROAD BASE  
THICKNESS) IF SPECIFIED FOR NEW  
STREET CONSTRUCTION.

\*\*WHERE ANY PORTION OF  
TRENCH EXCAVATION FALLS  
WITHIN SHOULDER LIMITS,  
RESTORE SHOULDER FOR MIN.  
WIDTH OF 36" OR AS  
DIRECTED BY CITY.

CLASS 'C'  
GRAVEL SHOULDER  
RESTORATION

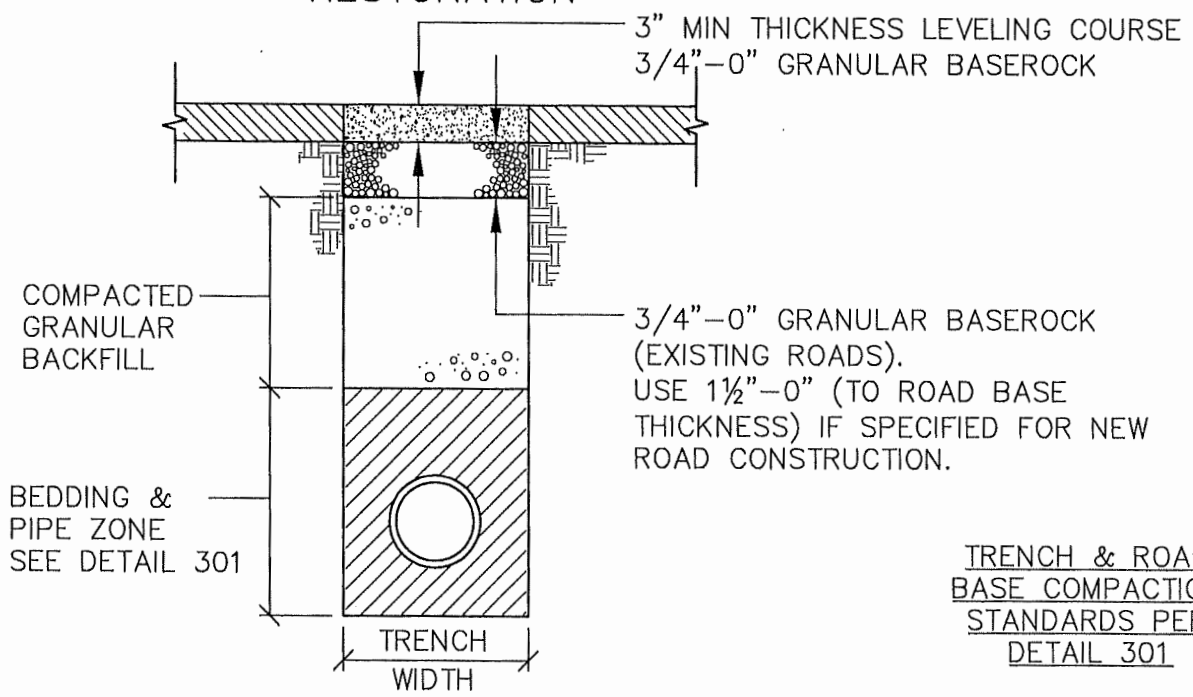

3" MIN THICKNESS LEVELING COURSE  
3/4"-0" GRANULAR BASEROCK

3/4"-0" GRANULAR BASEROCK  
(EXISTING ROADS).  
USE 1 1/2"-0" (TO ROAD BASE  
THICKNESS) IF SPECIFIED FOR NEW  
ROAD CONSTRUCTION.

TRENCH & ROAD  
BASE COMPACTION  
STANDARDS PER  
DETAIL 301

CLASS 'D'  
GRAVEL STREET  
RESTORATION

NOTES:

1. SHOULDER ROCK TO BE COMPACTED TO ROAD BASEROCK STANDARDS.

LAST REVISION DATE: DEC 2015	
GRAVEL SURFACE RESTORATION	
(NTS)	
NOSD, OR	DETAIL NO. 303

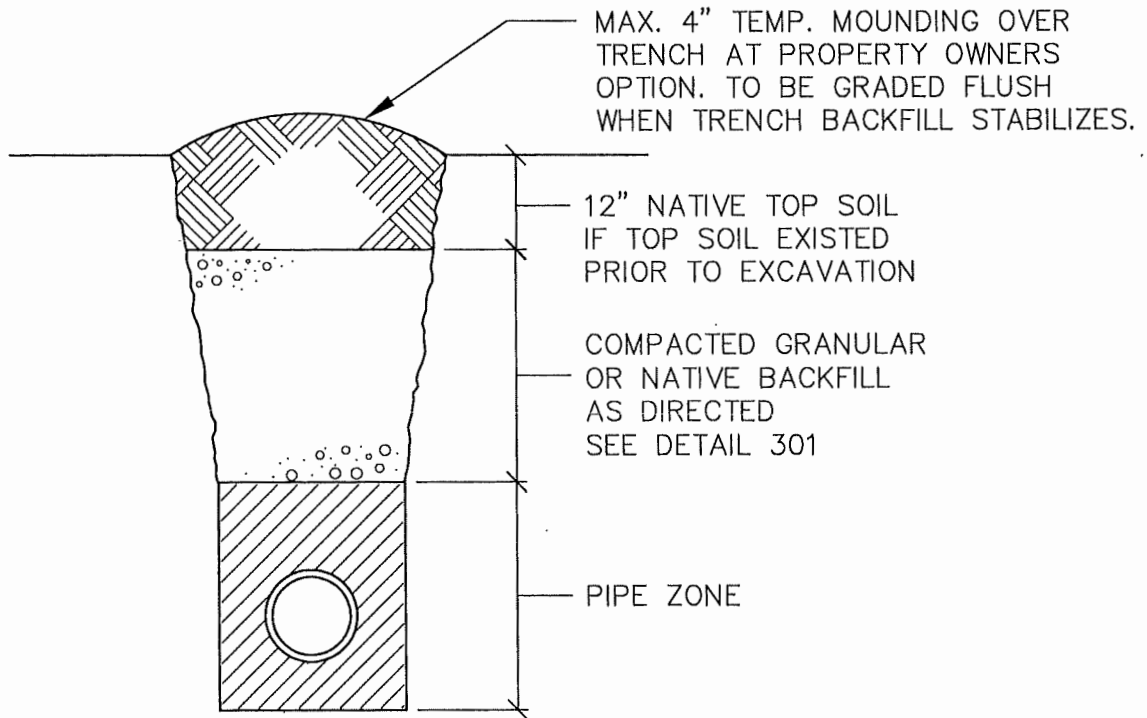

CLASS 'E'  
UNIMPROVED & OPEN AREAS

TRENCH & ROAD  
BASE COMPACTION  
STANDARDS PER  
DETAIL 301

NOTES:

1. ANY TRENCH SETTLEMENT DURING WARRANTY PERIOD SHALL BE CORRECTED AT CONTRACTOR'S EXPENSE, INCLUDING SURFACE RESTORATION.

LAST REVISION DATE: DEC 2015	
NATIVE SURFACE RESTORATION	
(NTS)	
NOSD, OR	DETAIL NO. 304

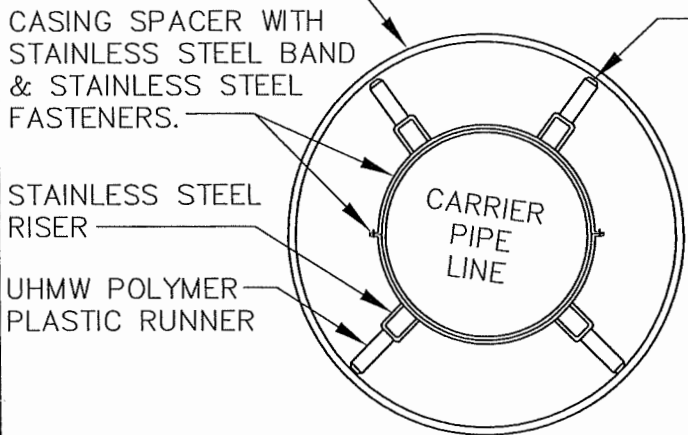
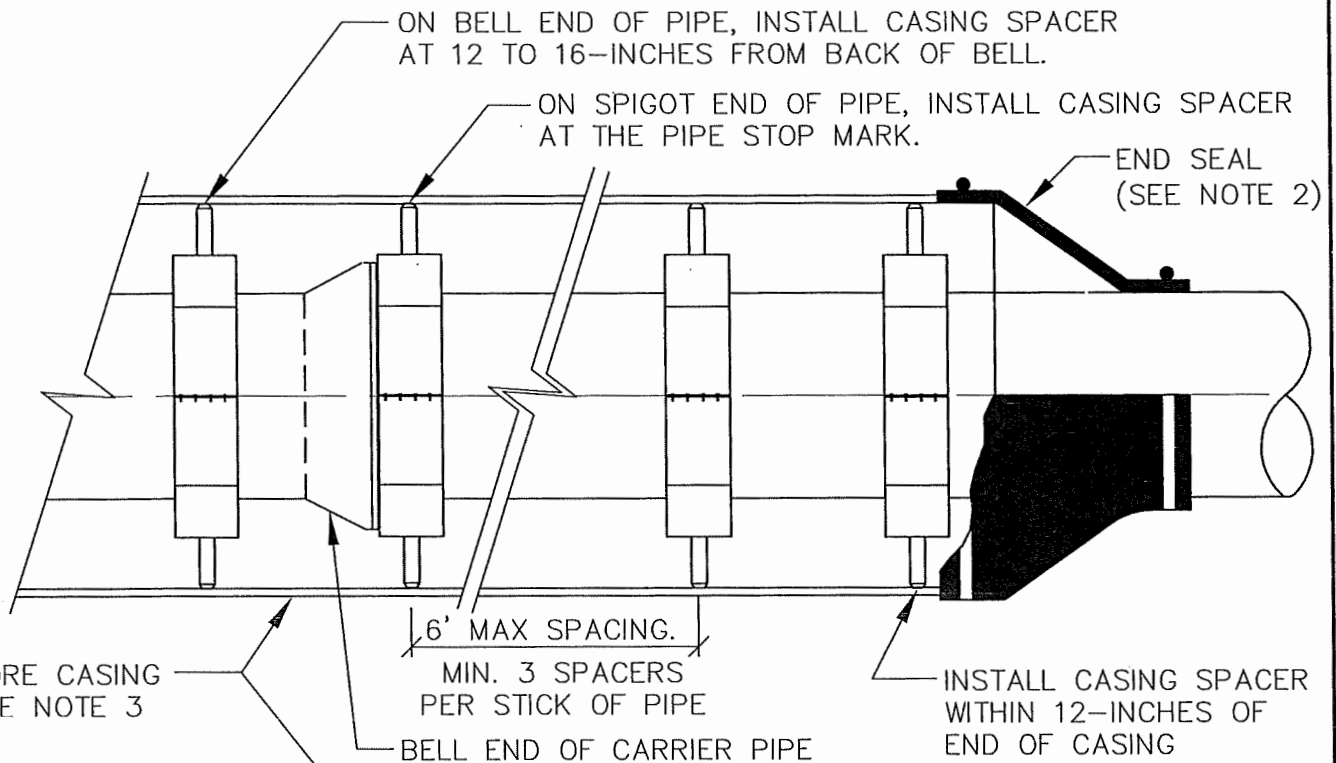

SEE NOTE 5 FOR BORE FILL REQUIREMENTS FOR GRAVITY CARRIER PIPES.

CARRIER PIPE DIAMETER	MIN. DIA. CASING (*1, *2)	MIN CASING WALL THICKNESS (INCH)
6"	12"	0.25 (1/4)
8"	14"	0.25 (1/4)
10"	16"	0.312 (5/16)
12"	18"	0.375 (3/8)

\*1: CASING SIZE LISTED IS FOR PRESSURE PIPE. LARGER DIA CASING REQ'D FOR GRAVITY PIPE.  
\*2: SEE PWDS 5.8.o FOR GRAVITY PIPE CASING SIZE REQUIREMENTS OR LARGER CASING SIZES.

**NOTES:**

- CASING SPACERS – APS MODEL SSI, CALPICO M-SS SERIES OR APPROVED EQUAL. FOR 4"–18" CARRIER PIPE, USE 8" WIDE BAND. FOR >18" CARRIER PIPE, USE 12" WIDE BAND.
- SEAL BOTH ENDS OF BORE CASING WITH END SEALS. WITHOUT SAND FILL, USE APS MODEL AZ OR APPROVED EQUIV. FASTEN TO CASING AND CARRIER PIPE WITH ST. STEEL BANDS. WITH SAND FILL, USE GROUT END CAPS (PLUG VENT TUBES AFTER SAND FILL).
- CASING SHALL BE WELDED SMOOTH STEEL PIPE CONFORMING TO ASTM A-53, GRADE B OR APPROVED EQUIVALENT ( $F_y = 35,000$  psi).
- SEE DRAWINGS FOR MINIMUM CARRIER PIPE DIAMETER, THICKNESS & MATERIAL.
- INCREASE CASING DIA AS REQ'D TO ALLOW TRIMMING OF CASING SPACERS ON GRADE CRITICAL BORES
- FOR GRAVITY SEWER OR STORM CARRIER PIPES, THE CASING ANNULAR SPACE SHALL BE COMPLETELY FILLED WITH SAND TO PREVENT FLOATATION OF CARRIER PIPE BY GROUNDWATER.
- CARRIER PIPE SHALL BE COMPLETELY FILLED WITH WATER PRIOR TO INSTALLING OR BLOWING SAND (ANTIFLOATATION).

LAST REVISION DATE: MAR 2024	COPYRIGHT 1996 WESTECH ENGINEERING, INC.
<b>BORE CASING, CARRIER PIPE AND CASING SPACER DETAIL</b> (NTS)	
NOSD, OR	DETAIL NO. 308

NOTE: PER ORS 92.044(7), MANHOLE MUST BE SET 1' MINIMUM CLEAR FROM ANY SURVEY MONUMENT

PROVIDE GASKETED PVC CAP ON ALL STUBS FOR FUTURE CONNECTION SHOWN ON DWGS (EXTEND PIPE 2' MIN BEYOND MH WALL), SLOPE PER DWGS.

**TYP DROP THRU MH:**

0.1' MIN STRAIGHT, 0.2' MIN CORNERS, SMALLER INLET PIPES TO MATCH LARGER OUTLET CROWN

INVERT ELEVATIONS PER DRAWINGS

O-RING or BUTYL RESIN MASTIC AS SPEC'D

OFFSET JOINT

BUTYL RESIN MASTIC

KEYLOCK JOINT

VACUUM TESTING OF EXTG MANHOLES REQUIRED AFTER NEW CONNECTIONS. SEAL MH AS REQUIRED TO PASS.

SLOPE SHELVES 1:12 TO DRAIN

ALL INSIDE JOINTS & PENETRATIONS SHALL BE GROUTED SMOOTH AFTER MH ASSEMBLY, SO AS NOT TO RETAIN DEBRIS OR SEDIMENT (TYP ALL).

ALL SS MHS. CLEAN & INSTALL 9" WIDE EXTERNAL MASTIC WRAP AT ALL JOINTS & PICKHOLES (TRELLEBORG OR BESTWRAP), SECURE IN PLACE W/ 3 LAYERS OF PLASTIC PALLET WRAP. CONTACT PUBLIC WORKS FOR INSPECTION BEFORE BACKFILLING.

STEPS. VERIFY LOCATION TO AVOID CONFLICTS WITH INSIDE OR OUTSIDE DROPS

MANHOLE FRAME & COVER, SET PER DTL 407

**PLAN**

MANPAN MH LID INSERT AS REQ'D (SEE DTL 407)

PAVED SURFACE

SET FRAME IN NON-SHRINK GROUT

UNPAVED

GRADE RINGS (VARIABLE) 18" MAX. - TOP OF CONE TO RIM

**MANHOLE BARREL JOINT OPTIONS & SEALING**

SLOPE OF PRECAST ECCENTRIC CONE SHALL FACE DOWN GRADE. LOCATE STEPS ON UPSTREAM SIDE OF MANHOLE.

30" MAX  
8" MIN  
12" TYP

MASTIC WRAP AS NOTED

WALL THICKNESS PER ASTM C-478

ALL OPENINGS CORED DRILLED.

48" INSIDE DIA. MIN (VERIFY ID BASED ON PIPE SIZE & CONFIG.)

CHANNEL DEPTH = 2/3 PIPE DIA. MIN.

**FLAT TOP MH'S SHALL BE USED FOR ALL MH'S LESS THAN 6' RIM TO INVERT, OR WITH TOP OF PIPE CONNECTIONS WITHIN 5 FEET OF RIM ELEV**

ALL PIPE PENETRATIONS ON SANITARY SEWER MANHOLES TO HAVE RUBBER BOOTS.

ROUTE TONING WIRE UP OUTSIDE OF MH AS SHOWN (TYP ALL PIPES).

18" MAX

FLOW

PRECAST BASE THICKNESS PER ASTM C-478

6" MIN COMPACTED GRANULAR BEDDING

STABLE SUBGRADE

**SECTION A-A**

**NOTES:**

1. PRECAST SECTIONS SHALL MEET OR EXCEED ASTM C-478. ALL CHANNELS & GROUTING TO BE SMOOTH.
2. WATERTIGHT O-RING OR MASTIC JOINTS REQUIRED, W/EXTERNAL SEAL AT BARREL JOINTS & PICKHOLES.
3. STEPS TO BE POLYPROPYLENE PLASTIC WITH GRADE 60 REINFORCING ROD. ADD STEPS TO EXTG CONNECTION MH IF EXTG STEPS ARE ABSENT.

LAST REVISION DATE: SEPT 2025	COPYRIGHT 1996 WESTECH ENGINEERING, INC.
<b>STANDARD MANHOLE FOR 21" PIPE AND SMALLER</b>	
(NTS)	
NOSD, OR	DETAIL NO. 401

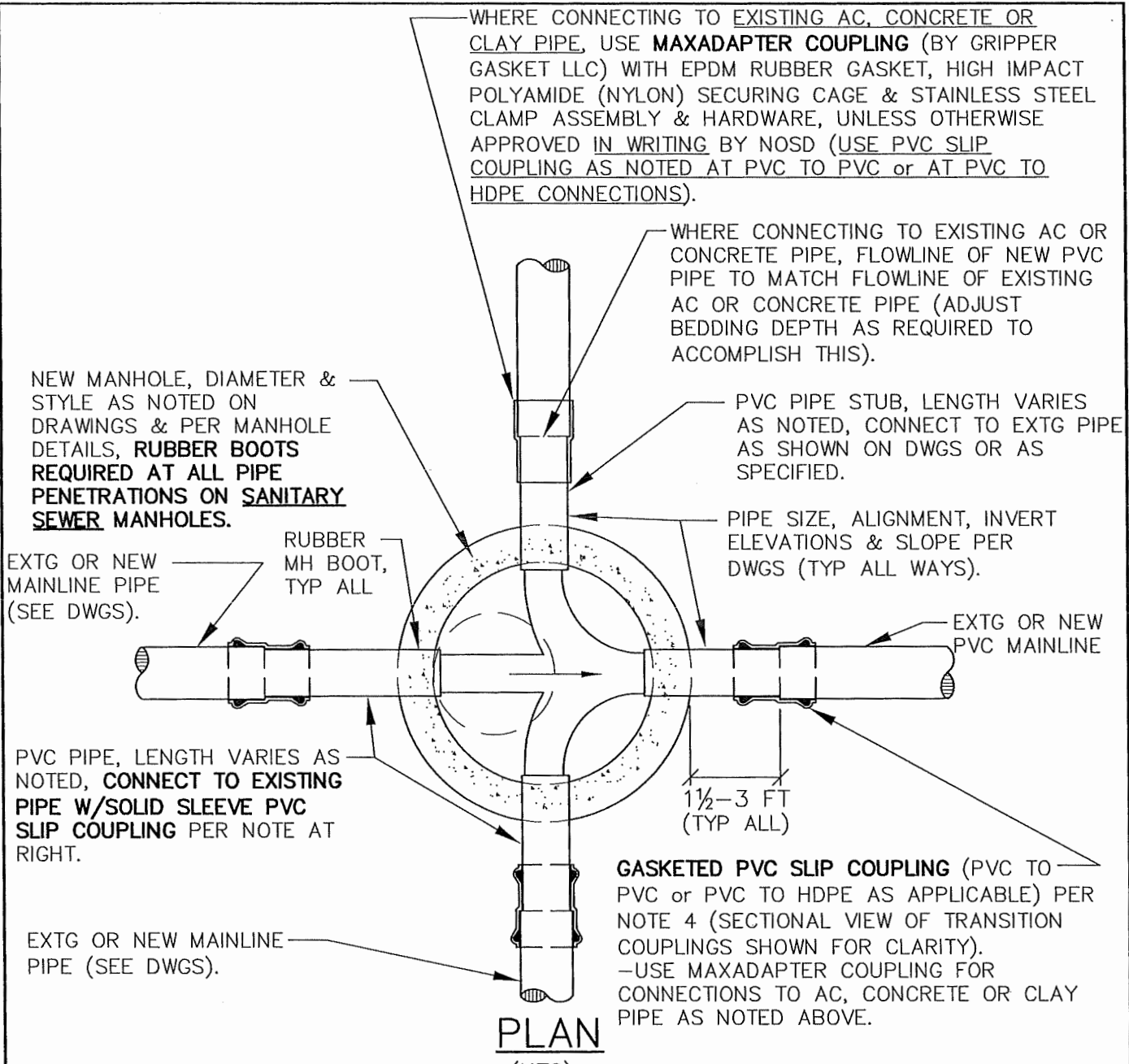

**NOTES:**

1. NEW MANHOLES TO FULLY CONFORM WITH STANDARD MANHOLE DETAILS & DRAWING CALLOUTS.
2. GASKETED PVC SLIP COUPLING SHALL BE SIZED FOR ACTUAL O.D. OF EACH PIPE USED (CONTRACTOR TO VERIFY AS NECESSARY).
3. POST CONSTRUCTION TV INSPECTION SHALL INCLUDE A VIEW OF ALL JOINTS WHERE NEW PIPE STUB IS CONNECTED TO EXISTING PIPE (**TV INSPECT ALL WAYS AT EACH NEW MANHOLE**).
4. GASKETED PVC SLIP COUPLINGS TO BE SOLID-SLEEVE NO-STOP COUPLING DESIGNED TO BE SLID FULLY ONTO PIPE ON ONE SIDE OF JOINT, THEN SLID BACK OVER AND CENTERED ON JOINT (BY SPECIFIED FITTINGS, PLASTIC TRENDS, OR APPROVED EQUAL).
5. UNLESS OTHERWISE SPECIFICALLY NOTED ON DWGS, WHEN NEW PIPE AT MH IS LARGER THAN EXISTING PIPE, INSTALL GASKETED ECCENTRIC REDUCER WITH PIPE STUBS AS REQ'D TO MAINTAIN UNIFORM FLOW LINE THRU CONNECTION.
6. VACUUM TESTING OF MANHOLES REQUIRED AFTER NEW CONNECTIONS ARE MADE & FINAL SURFACE RESTORATION IS COMPLETED. SEAL MH AS REQUIRED TO PASS VACUUM TEST **AND** TO ELIMINATE ALL VISIBLE LEAKAGE.
7. MH STEPS PER STANDARD MH DETAILS.

LAST REVISION DATE: SEPT 2024	JOB#
<b>CONNECTION AT NEW MH'S &amp; OTHER TRANSITION POINTS (SANITARY SEWER)</b> (NTS)	
NOSD, OR	DETAIL NO. 401A

NOTE: PER ORS 92.044(7), MANHOLE MUST BE SET 1' MINIMUM CLEAR FROM ANY SURVEY MONUMENT

PROVIDE GASKETED PVC CAP ON ALL STUBS FOR FUTURE CONNECTION SHOWN ON DWGS (EXTEND PIPE 2' MIN BEYOND MH WALL), SLOPE PER DWGS.

**TYP DROP THRU MH:**  
 0.1' MIN STRAIGHT,  
 0.2' MIN CORNERS,  
 SMALLER INLET PIPES  
 TO MATCH LARGER  
 OUTLET CROWN

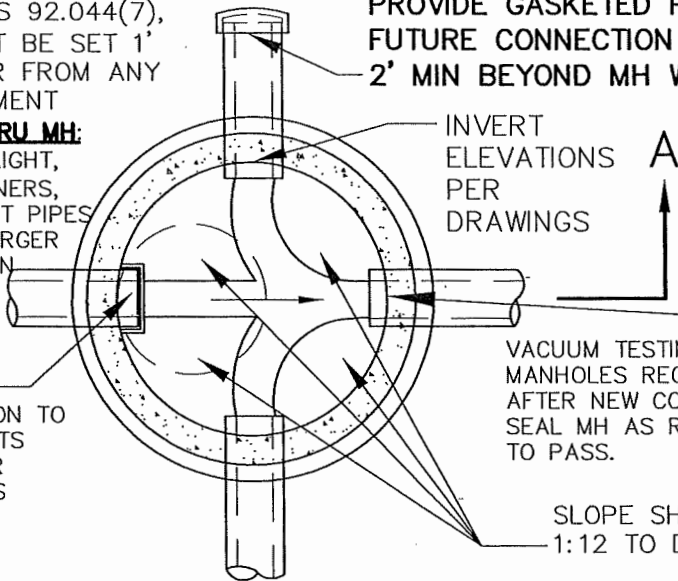

**PLAN**

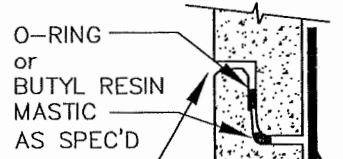

OFFSET JOINT

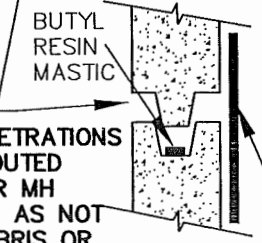

KEYLOCK JOINT

ALL INSIDE JOINTS & PENETRATIONS SHALL BE GROUTED SMOOTH AFTER MH ASSEMBLY, SO AS NOT TO RETAIN DEBRIS OR SEDIMENT (TYP ALL).

**MANHOLE BARREL JOINT OPTIONS & SEALING**

ALL SS MHS. CLEAN & INSTALL 9" WIDE EXTERNAL MASTIC WRAP AT ALL JOINTS & PICKHOLES (TRELLEBORG OR BESTWRAP), SECURE IN PLACE W/ 3 LAYERS OF PLASTIC PALLET WRAP. CONTACT PUBLIC WORKS FOR INSPECTION BEFORE BACKFILLING.

STEPS. VERIFY LOCATION TO AVOID CONFLICTS WITH INSIDE OR OUTSIDE DROPS

VACUUM TESTING OF EXTG MANHOLES REQUIRED AFTER NEW CONNECTIONS. SEAL MH AS REQUIRED TO PASS.

SLOPE SHELVES 1:12 TO DRAIN

MANHOLE FRAME & COVER, SET PER DTL 407

MANPAN MH LID INSERT AS REQ'D (SEE DTL 407)

SET FRAME IN NON-SHRINK GROUT

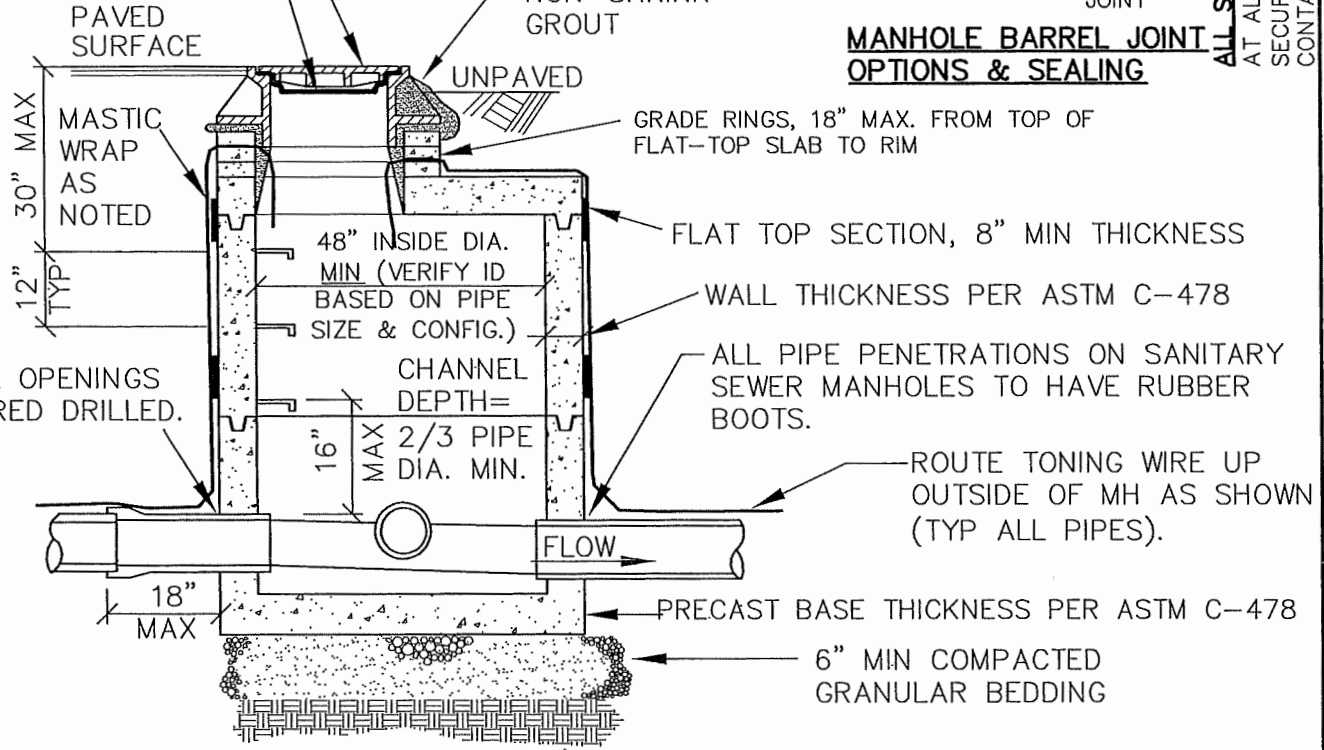

**SECTION A-A**

**NOTES:**

1. PRECAST SECTIONS SHALL MEET OR EXCEED ASTM C-478. ALL CHANNELS & GROUTING TO BE SMOOTH.
2. WATERTIGHT O-RING OR MASTIC JOINTS REQUIRED, W/EXTERNAL SEAL AT BARREL JOINTS & PICKHOLES.
3. STEPS TO BE POLYPROPYLENE PLASTIC WITH GRADE 60 REINFORCING ROD. ADD STEPS TO EXTG CONNECTION MH IF EXTG STEPS ARE ABSENT.

LAST REVISION DATE: OCT 2025	COPYRIGHT 1996 WESTECH ENGINEERING, INC.
<b>FLAT TOP MANHOLE FOR 21" PIPE AND SMALLER</b>	
(NTS)	
NOSD, OR	DETAIL NO. <b>402</b>

**INSIDE DROP REQ'D FOR SS MH'S WITH INLET TO OUTLET INVERT DIFFERENCE GREATER THAN 18"**

**INSIDE DROP NOT ALLOWED FOR INLET PIPES >12" W/OUT VARIANCE FROM NOSD**

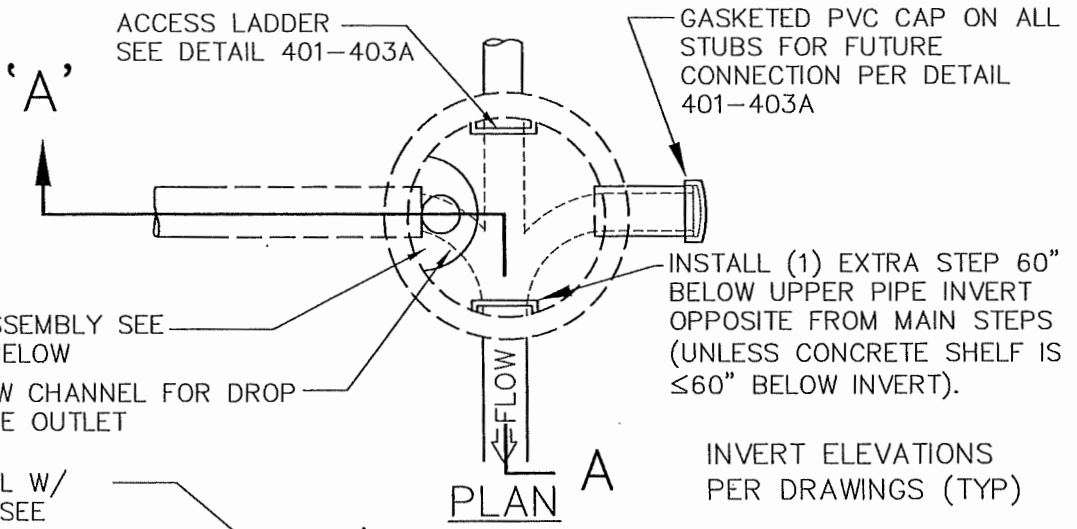

DROP ASSEMBLY SEE DETAIL BELOW

NEW CHANNEL FOR DROP PIPE OUTLET

INSIDE DROP BOWL W/ S.S. FASTENERS, SEE NOTE 2

MANHOLE PENETRATION TO BE CORE DRILLED & BOOTED PER NOTE 3.

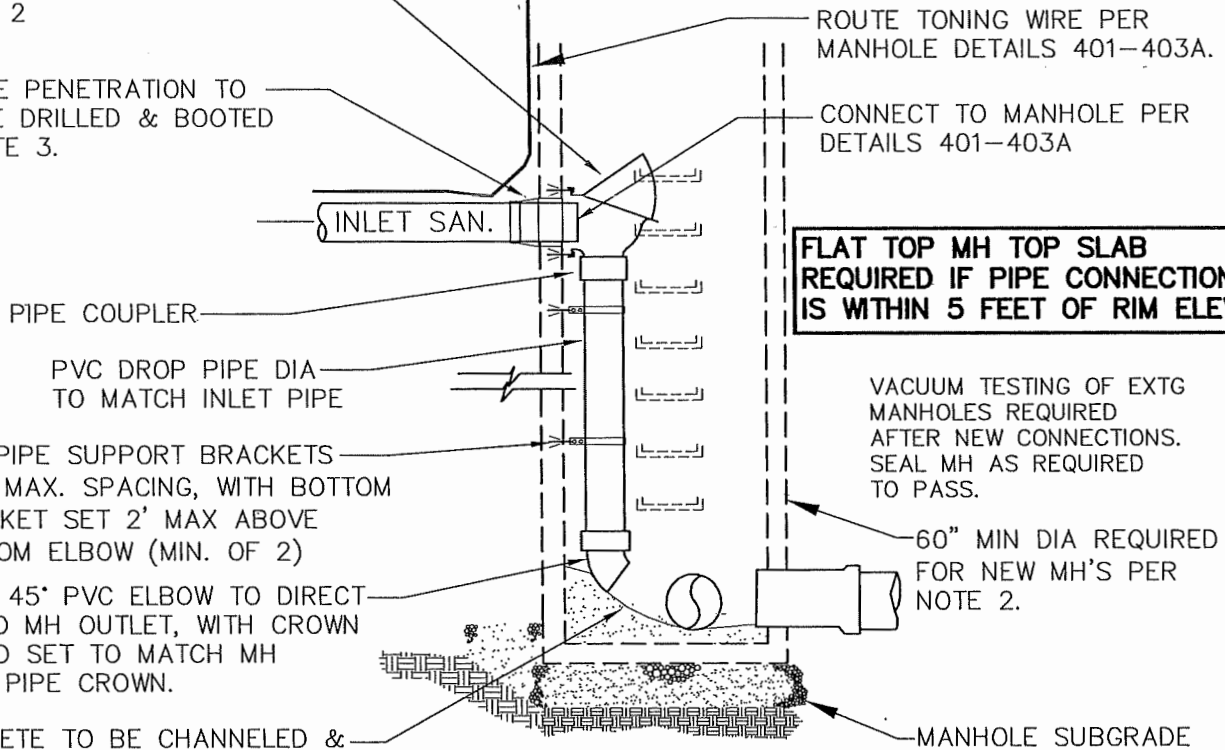

**SECTION A-A**

**NOTES:**

1. ALL INSIDE DROPS MUST BE APPROVED ON A CASE BY CASE BASIS BY THE PUBLIC WORKS DIRECTOR.
2. MINIMUM 60" DIAMETER MANHOLE REQUIRED FOR INSIDE DROPS UNLESS OTHERWISE APPROVED IN WRITING BY THE PUBLIC WORKS DIRECTOR.
3. PROVIDE "RELINER" INSIDE DROP BOWL BY DURAN, INC. OR APPROVED EQUAL. PROVIDE DROP BOWL WITH OPTIONAL HOOD AS SHOWN (A) WHERE NOTED ON DRAWINGS, (B) FOR FORCE MAIN CONNECTIONS, (C) FOR INLET PIPES WITH SLOPES GREATER THAN 5%, OR (D) WHERE REQUIRED BY PUBLIC WORKS.
4. MANHOLE BASE, BARREL & TOP TO CONFORM WITH DETAILS 401-403A (INCLUDING FLAT TOP REQUIREMENT IF TOP OF DROP PIPE IS WITHIN 5' OF MANHOLE RIM).

5. STEPS TO BE POLYPROPYLENE PLASTIC WITH GRADE 60 REINFORCING ROD. INSTALL NEW STEPS IN EXISTING MH BEING CONNECTED TO IF STEPS ARE ABSENT.

LAST REVISION DATE: MAR 2026	
<b>INSIDE DROP CONNECTION FOR SANITARY SEWER OR STORM MANHOLE</b>	
(NTS)	
NOSD, OR	DETAIL NO. <b>404</b>

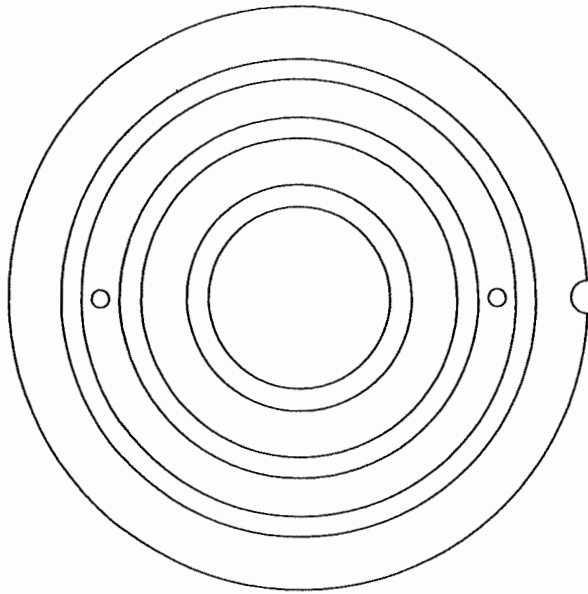

SANITARY

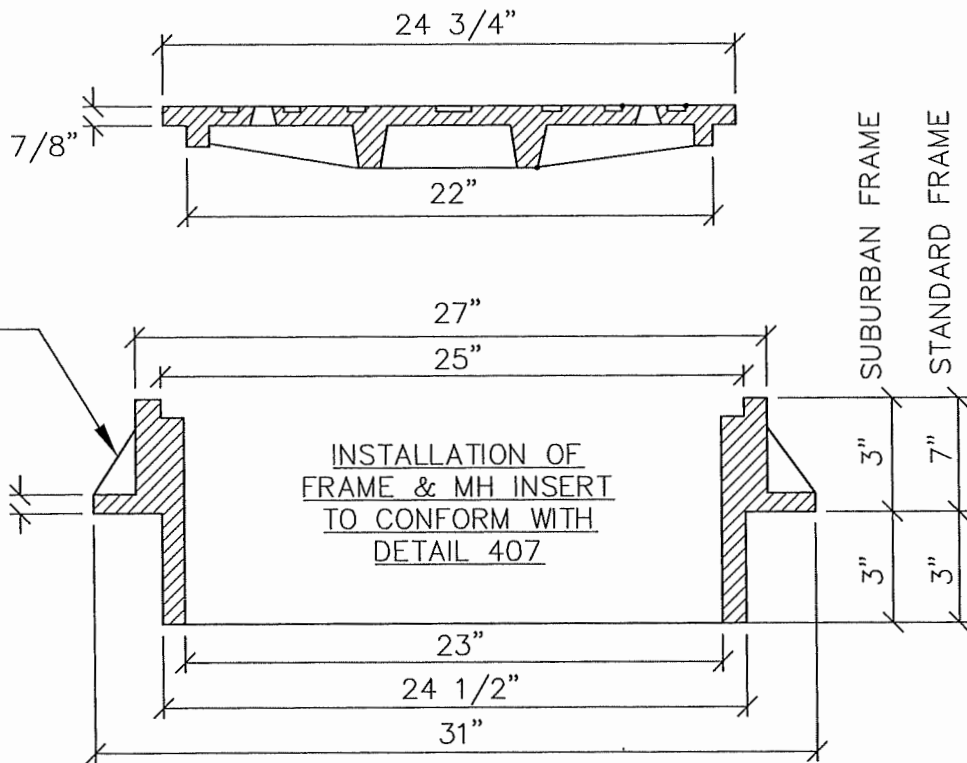

NOTES:

1. COVER AND FRAME SHALL BE GRAY CAST IRON PER ASTM A-48, CLASS 30.
2. COVER AND FRAME TO BE MACHINED TO PROVIDE A TRUE BEARING SURFACE ALL AROUND.
3. NOTCH LID FOR LIFTING HOOK.
4. NON-LOCKDOWN STYLE TYPICAL. BOLTDOWN/LOCKDOWN LIDS ARE PROHIBITED EXCEPT WHERE EXPLICITLY NOTED ON THE APPROVED DWGS. BOLTDOWN/LOCKDOWN LIDS WHICH ARE INSTALLED WHERE NOT NOTED/SPECIFIED SHALL BE REPLACED BY CONTACTOR AT NO ADDED COST TO NOSD.
5. ADJUSTABLE MANHOLE FRAME BY RIM RISER OR APPROVED EQUAL MAY BE USED. SEE DTL 405A.

LAST REVISION DATE: SEPT 2024	
<b>MANHOLE FRAME AND COVER (STANDARD AND SUBURBAN)</b>	
(NTS)	
NOSD, OR	DETAIL NO. <b>405</b>

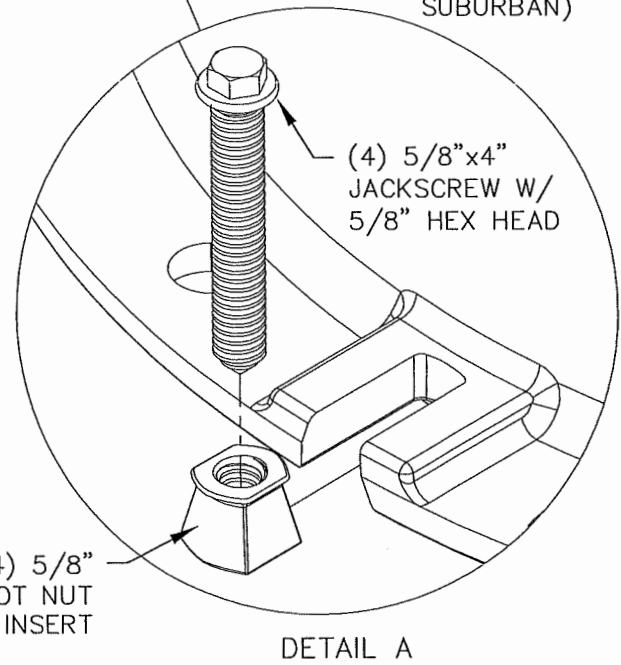
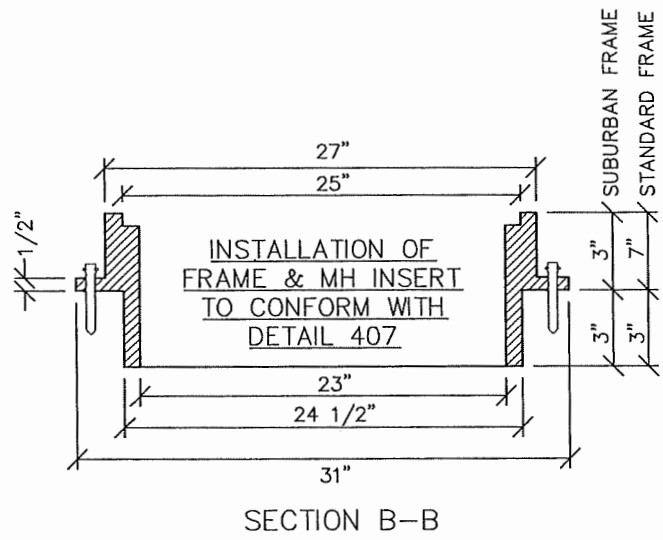
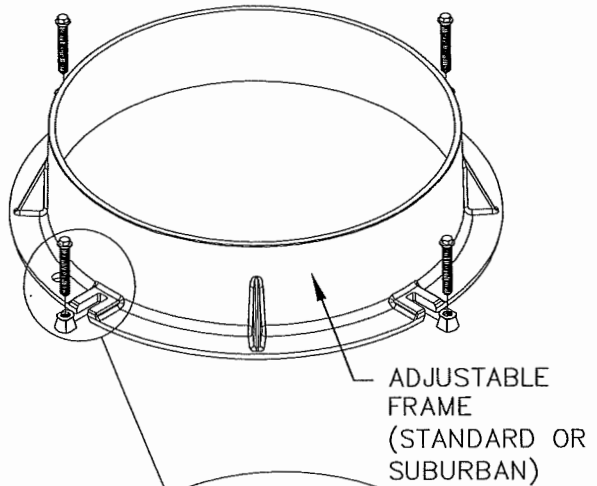
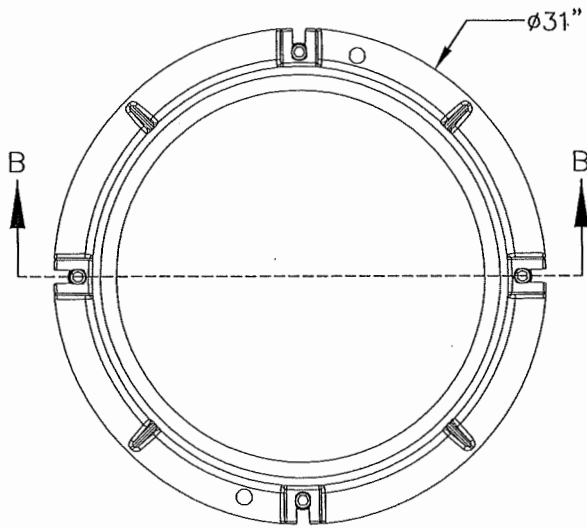

**NOTES:**

1. ADJUSTABLE MANHOLE FRAMES MUST BE SHOWN ON THE DESIGN DRAWINGS OR AS-BUILT DRAWINGS.
2. NO SHIMS REQUIRED ADJUST SCREWS TO MEET FINISH GRADE.
3. CASTING ASSEMBLY: AASHTO M-306 CERTIFIED, H-20 OR "TRAFFIC-RATED".
4. CASTINGS: GRAY IRON CONFORMS TO ASTM A48 CL35B.
5. SCREWS: ZINC PLATED, MILD STEEL CONFORMS TO ASTM A1018.
6. NUTS: ZINC ALLOY CONFORMS TO ASTM C41A.
7. FILL AND PACK GAP BETWEEN FRAME AND SUPPORTING BASE WITH NON-SHRINK GROUT AND FINISH SMOOTH/FLUSH WITH INTERIOR AND EXTERIOR OF ADJOINING SURFACES PER DETAIL 4070.
8. MANUFACTURER TO BE RIMRISER OR APPROVED EQUAL.
9. USE ONLY PARTS PROVIDED BY THE MANUFACTURER.
10. SEE DETAIL 405 FOR MANHOLE LID (SEWER OR STORM).

LAST REVISION DATE: SEPT 2024	
<b>ADJUSTABLE MANHOLE FRAME (RIM-RISER)</b>	
(NTS)	
NOSD, OR	DETAIL NO. <b>405A</b>

SLOT FOR SCREWDRIVER

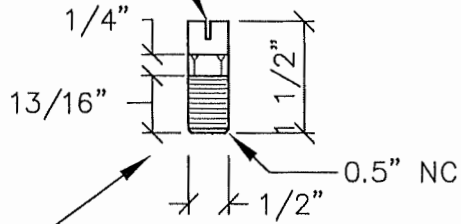

LOCATING STUD,  
DRILL 25/64" HOLE  
& TAP FOR 1/2" STUD  
(ONE PER COVER)

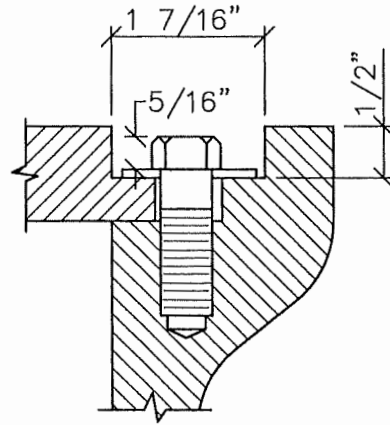
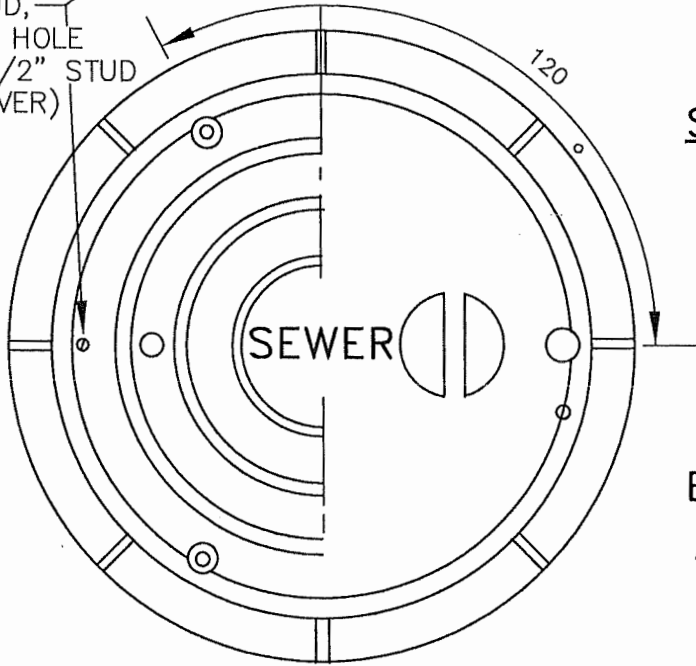

**SECTION B-B**

1/2"-13NCx1"  
STAINLESS STEEL  
HEX HEAD  
CAP SCREW

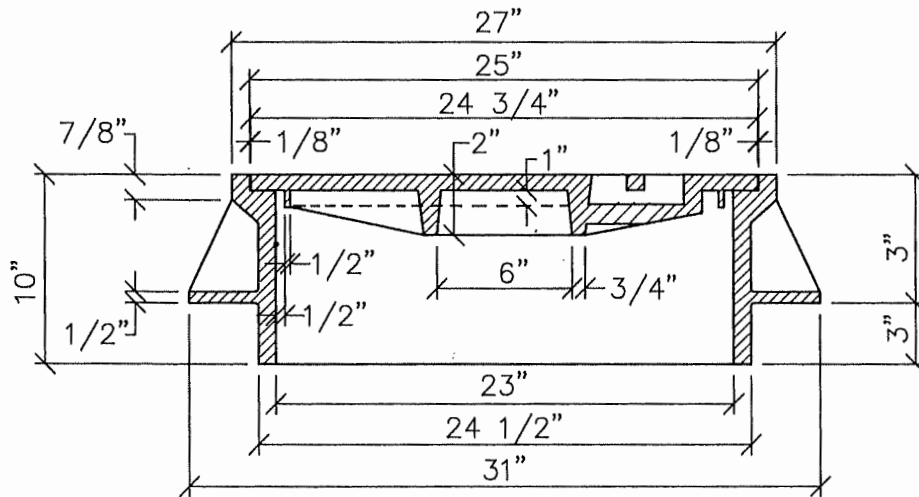
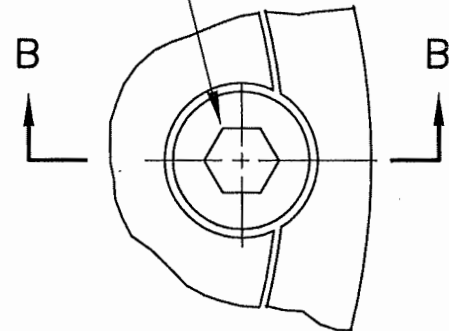

**SECTION A-A**

INSTALLATION OF  
FRAME & MH INSERT  
TO CONFORM WITH  
DETAIL 407

**NOTES:**

1. COVER AND FRAME TO BE MACHINED TO A TRUE BEARING ALL AROUND.
2. MATERIAL SHALL BE OF GRAY CAST IRON, ASTM A-48, CLASS 30.
3. LOCKDOWN FRAME & COVER SHALL BE USED ONLY WHERE SPECIFICALLY REQUIRED BY NOSD SUPERINTENDENT.

LAST REVISION DATE: DEC 2015	COPYRIGHT 1996 WESTECH ENGINEERING, INC.
<b>LOCKDOWN MANHOLE FRAME + COVER</b>	
(NTS)	
NOSD, OR	DETAIL NO. 406

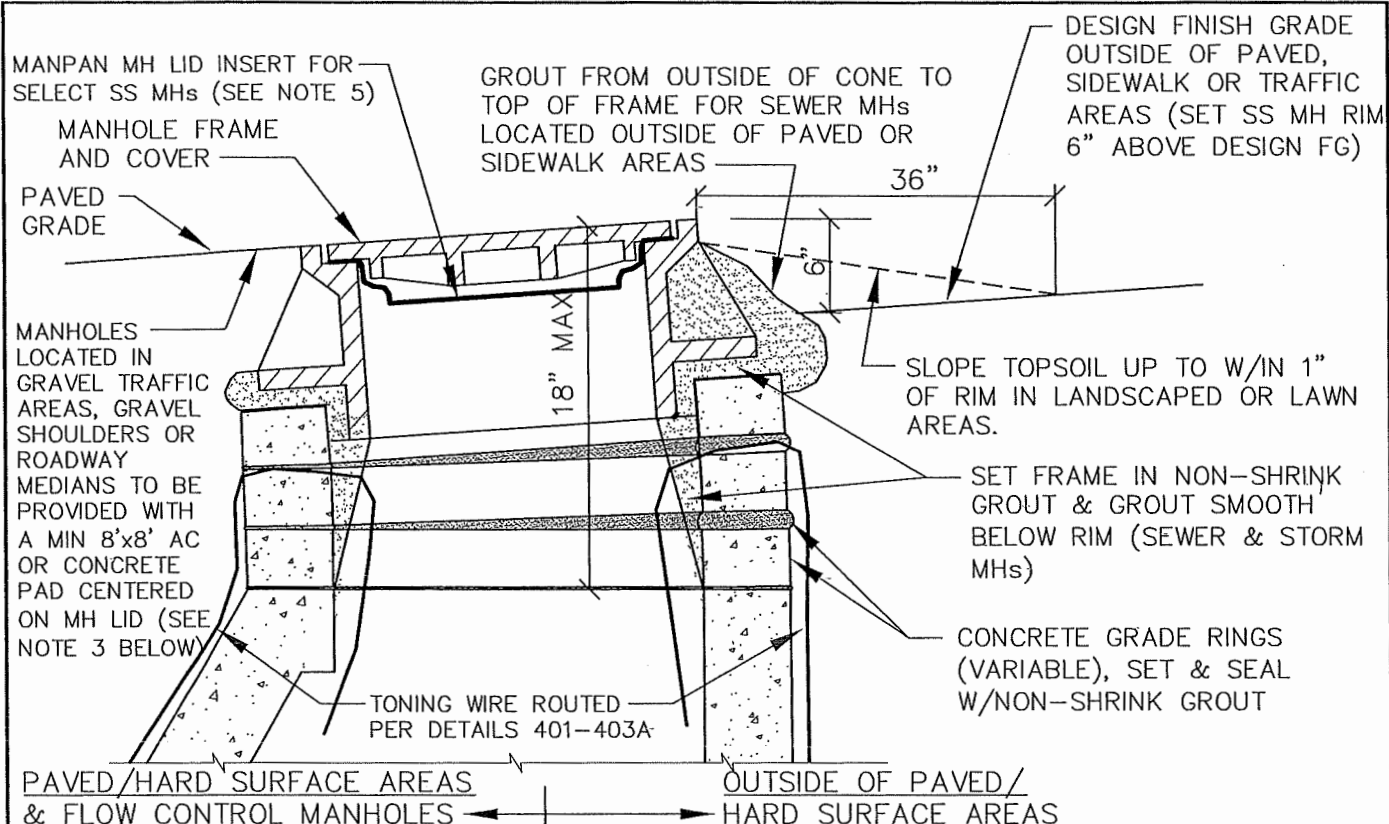

**TYPICAL MANHOLE GRADE ADJUSTMENT**

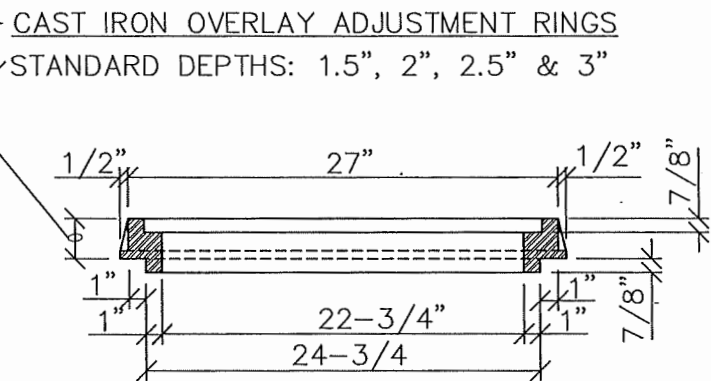
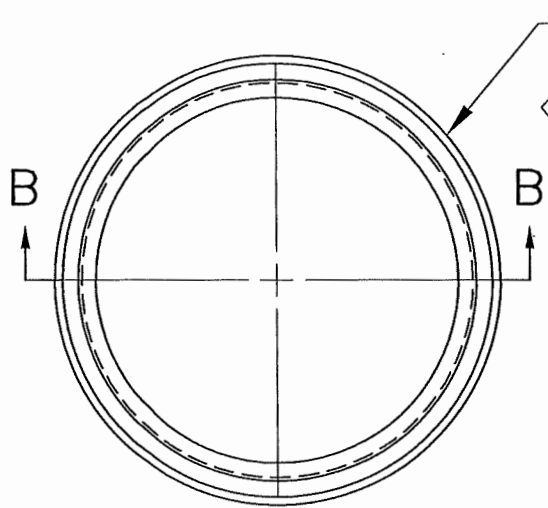

**SECTION B-B**

**MANHOLE ADJUSTMENT RINGS FOR RESURFACING ONLY**

**NOTES:**

1. CAST IRON ADJUSTMENT RINGS ALLOWED ONLY WITH OVERLAYS AND **NOT ON NEW MANHOLES**. MAXIMUM 1 ADJUSTMENT RING PER MANHOLE.
2. SANITARY SEWER MHs - 2 HOLE LIDS  
STORM DRAIN MHs - 16 HOLE LIDS
3. MH PADS IN UNPAVED TRAFFIC AREAS (OR FLOW CONTROL MH) - 8'x8' MIN SIZE OF (A) 3" MIN. AC OVER 10" COMPACTED BASEROCK (OR PUBLIC ROAD STANDARD THICKNESS IF LOCATED IN R.O.W), OR (B) 8" CONCRETE OVER 2" BACKROCK.
4. MH PADS IN ROAD MEDIAN PLANTER AREAS - 4" CONC (PER DTL 212, 10' MIN SQUARE W/5' SCORING PATTERN).

5. SEWER MHs IN LOW AREAS SUBJECT TO FLOODING OR WATER PONDING, ADJACENT TO CURBLINES OR DITCHES, ETC. SHALL BE PROVIDED WITH INFLOW PROTECTOR LID INSERTS (MAN PAN OR EQUAL). SEE CITY STANDARD CONSTRUCTION NOTES FOR LOCATION CRITERIA.

LAST REVISION DATE: OCT 2025	JO #
<b>MANHOLE RIM ADJUSTMENT DETAILS (CONCRETE GRADE RINGS)</b> (SEWER & STORM - NTS)	
NOSD, OR	DETAIL NO. 407

CLEANOUT COVERS: ALL SEWER CLEANOUT LIDS TO READ "SEWER"  
 ALL STORM CLEANOUT LIDS TO READ "STORM" OR "C/O".

24" SQUARE CONCRETE PAD  
 OR AC PAVEMENT OUTSIDE OF  
 PAVED AREAS. SLOPE AWAY  
 FROM CLEANOUT.

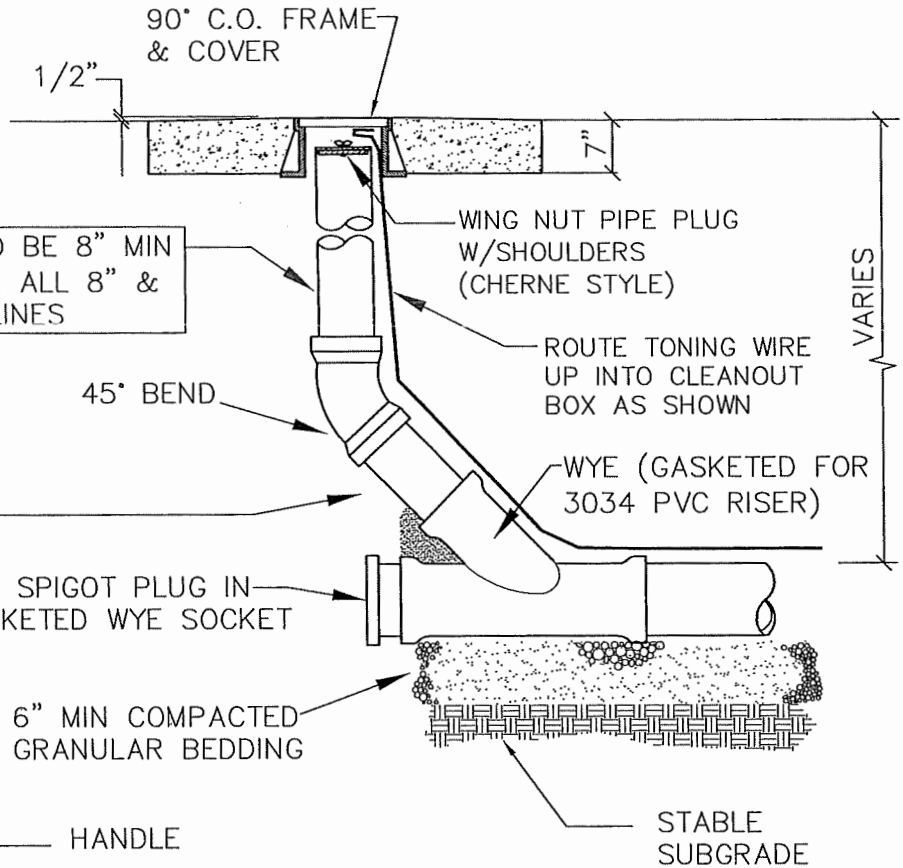
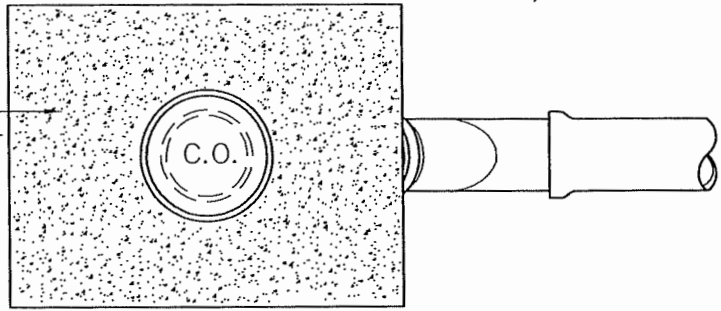

RISER PIPE TO BE 8" MIN  
 DIAMETER FOR ALL 8" &  
 LARGER MAINLINES

PIPE TO BEAR ON  
 COMPACTED GRANULAR  
 BACKFILL

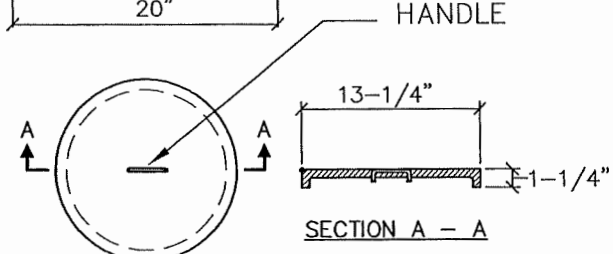
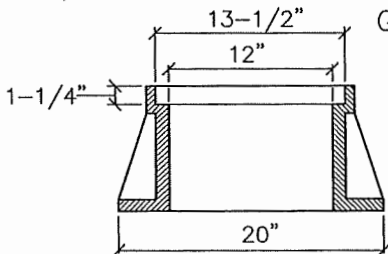

**CLEANOUT FRAME & COVER**

**NOTES:**

1. USE INLAND FOUNDRY MODEL 240 FRAME & COVER IN ALL AREAS.
2. COVER AND FRAME SHALL BE GRAY CAST IRON ASTM A-48, CLASS 30.
3. COVER AND FRAME TO BE MACHINED TO A TRUE BEARING ALL AROUND.

ALL CONCRETE SHALL BE 3300 PSI @ 28 DAYS, MAX 5" SLUMP, 4.5% AIR (±1.5%).

LAST REVISION DATE: MAY 2024	COPYRIGHT 1996 WESTECH ENGINEERING, INC.
<b>MAINLINE CLEANOUT</b>	
(NTS)	
NOSD, OR	DETAIL NO. 411

**NOTE: NO VERTICAL OR HORIZONTAL BENDS GREATER THAN 22-1/2° WITHIN RIGHT-OF-WAY OR PUBLIC UTILITY EASEMENT (IE. FROM MAINLINE TO CLEANOUT).**

PRESSURE TREATED 2" X 4" WIRED TO INVERT AND EXTENDING ABOVE FINISH GRADE. STAKE SHALL BE CONTINUOUS AND REMAIN VERTICAL AFTER BACKFILLING. END SHALL BE PAINTED (WHITE FOR SEWER) (GREEN FOR STORM), AND LABELED WITH DEPTH TO PIPE BELOW GROUND SURFACE (2" BLOCK LETTERS). EXTEND TONING WIRE TO SURFACE.

**NOTE: PER ORS 92.044(7), SERVICE LINES MUST BE SET 1' MINIMUM CLEAR FROM ANY SURVEY MONUMENT**

STAMP 3" TALL "S" OR "D" IN TOP OF CURB AND GUTTER PAN AT POINT OF CROSSING.

**NOTES:**

1. MIN. 18" SEPARATION BETWEEN ADJACENT LATERALS.
2. ONE FULL LENGTH OF PVC PIPE (AT CROSSING) REQUIRED FOR ALL SEWER LATERALS WHICH CROSS UNDER WATER LINES WITH LESS THAN 18" MINIMUM VERTICAL CLEARANCE BETWEEN WATER LINE AND SERVICE LATERAL.
3. SERVICE SHALL NOT BE BACKFILLED PRIOR TO INSPECTION BY PUBLIC WORKS.
4. INSTALL A CONTINUOUS 12 GAUGE SOLID CORE GREEN INSULATED TRACER WIRE FROM MAINLINE WIRE TO END OF LATERAL.
5. CHIMNEY DROPS INTO MAINLINES ARE PROHIBITED.
6. **COMMERCIAL** SEWER & STORM SERVICE LATERALS SHALL BE 6-INCH MINIMUM DIAMETER.
7. FERNCO STYLE COUPLINGS PROHIBITED BETWEEN MAINLINE CONNECTION & PROPERTY LINE C.O. (PVC SLIP COUPLING OR MAXADAPTER COUPLING REQ'D).

**TYPICAL, SHALLOW MAINS**

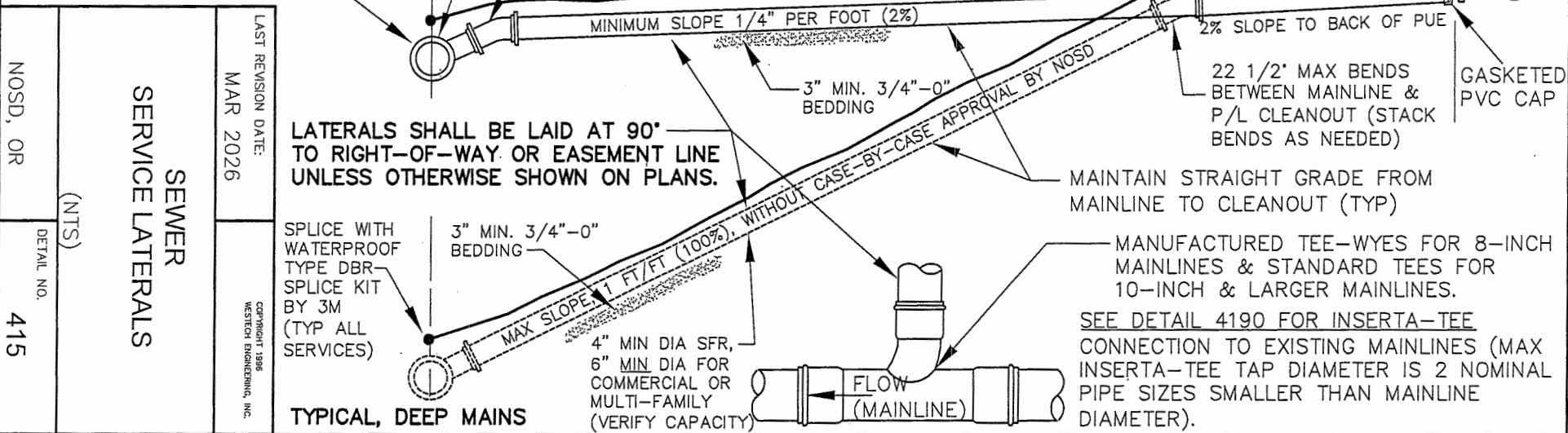

EASEMENT LINE OR P/L  
 PUE WHERE PROVIDED  
 24" MIN LATERALS CROSS WATERLINE (SEE NOTE 2)  
 SEWER: 48" MIN. COVER W/ NO WATERLINE  
 CONNECT PIPE FROM BUILDING / SITE TO BASE LEG OF CLEANOUT WYE (CONNECTION TO CLEANOUT RISER IS PROHIBITED).  
 12" MIN.  
 18" MAX.  
 TONER WIRE  
 6' UNDERGROUND WARNING TAPE "WARNING, SEWER LINE BELOW" OR "WARNING, STORM DRAIN BELOW" AS APPLICABLE  
 SEWER/STORM LATERAL 3034 PVC, SDR 35  
 22 1/2° MAX BENDS BETWEEN MAINLINE & P/L CLEANOUT (STACK BENDS AS NEEDED)  
 2% SLOPE TO BACK OF PUE  
 GASKETED PVC CAP

**LATERALS SHALL BE LAID AT 90° TO RIGHT-OF-WAY OR EASEMENT LINE UNLESS OTHERWISE SHOWN ON PLANS.**

SPLICE WITH WATERPROOF TYPE DBR SPLICE KIT BY 3M (TYP ALL SERVICES)

**TYPICAL, DEEP MAINS**

3" MIN. 3/4"-0" BEDDING

MAX SLOPE 1 FT/FT (100%) WITHOUT CASE-BY-CASE APPROVAL BY NOSD  
 4" MIN DIA SFR, 6" MIN DIA FOR COMMERCIAL OR MULTI-FAMILY (VERIFY CAPACITY)

MANUFACTURED TEE-WYES FOR 8-INCH MAINLINES & STANDARD TEES FOR 10-INCH & LARGER MAINLINES.

SEE DETAIL 4190 FOR INSERTA-TEE CONNECTION TO EXISTING MAINLINES (MAX INSERTA-TEE TAP DIAMETER IS 2 NOMINAL PIPE SIZES SMALLER THAN MAINLINE DIAMETER).

NOSD, OR

(NTS)

DETAIL NO.

415

SEWER SERVICE LATERALS

LAST REVISION DATE:

MAR 2026

COPYRIGHT 1996 WESTECH ENGINEERING, INC.

CUT-IN CONNECTIONS ALLOWED ONLY WHERE SPECIFICALLY APPROVED OR REQUIRED BY PUBLIC WORKS DIRECTOR AND CITY ENGINEER.

USE OF DETAIL 419 IS REQUIRED WHERE MAINLINE PIPE IS AT LEAST TWO NOMINAL PIPE SIZES LARGER THAN LATERAL PIPE DIAMETER.

WHERE CONNECTING TO EXISTING AC, CONCRETE OR CLAY PIPE, USE **MAXADAPTER COUPLING** (BY GRIPPER GASKET LLC) WITH EPDM RUBBER GASKET, HIGH IMPACT POLYAMIDE (NYLON) SECURING CAGE & STAINLESS STEEL CLAMP ASSEMBLY & HARDWARE, UNLESS OTHERWISE APPROVED IN WRITING BY CITY.

WHERE CONNECTING TO EXTG PVC OR HDPE PIPE, USE EITHER **MAXADAPTER COUPLING OR GASKETED PVC SLIP COUPLING** PER NOTE 2 BELOW (SECTIONAL VIEW OF PVC TRANSITION COUPLING SHOWN FOR CLARITY).

MANUFACTURED PVC TEE OR TEE-WYE PER DETAIL 415. PROVIDE COMPACTED BEDDING PER NOTE 4.

EXTG MAINLINE PIPE (SEE DWGS).

EXTG MAINLINE PIPE (SEE DWGS).

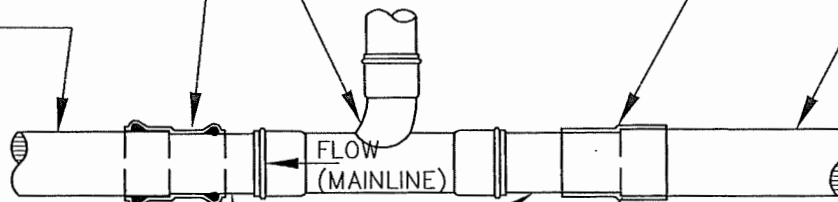

PVC PIPE SPOOL, MIN LENGTH AS REQUIRED FOR CLEAN CONNECTION TO EXTG PIPE.

WHERE CONNECTING TO EXISTING AC OR CONCRETE PIPE, FLOWLINE OF NEW PVC PIPE SHOULD MATCH FLOWLINE OF EXISTING AC OR CONCRETE PIPE (ADJUST BEDDING DEPTH AS REQUIRED TO ACCOMPLISH THIS).

**PLAN**  
(NTS)

**NOTES:**

1. CONTRACTOR SHALL PROVIDE BYPASS PUMPING AS REQUIRED TO AVOID SEWAGE BACKUPS IN UPSTREAM SYSTEM (BYPASS SYSTEM SHALL BE APPROVED BY PUBLIC WORKS).
2. WHERE USED, GASKETED PVC SLIP COUPLINGS SHALL BE SOLID-SLEEVE NO-STOP COUPLING DESIGNED TO BE SLID FULLY ONTO PIPE ON ONE SIDE OF JOINT, THEN SLID BACK OVER AND CENTERED ON JOINT (BY SPECIFIED FITTINGS, PLASTIC TRENDS, OR APPROVED EQUAL). GASKETED PVC SLIP COUPLING SHALL BE SIZED FOR ACTUAL O.D. OF EACH PIPE USED (CONTRACTOR TO FIELD VERIFY PIPE AS NECESSARY).
3. SERVICE LATERALS SHALL FULLY CONFORM WITH LATERAL DETAIL 415, DETAIL 416 & DRAWING CALLOUTS.
4. A MINIMUM OF 12-INCHES OF COMPACTED GRANULAR BEDDING IS REQUIRED UNDER THE CUT-IN TEE LOCATION TO PREVENT SETTLEMENT DURING OR AFTER BACKFILLING & COMPACTION.
5. **POST CONSTRUCTION TV INSPECTION** OF MAINLINE CONNECTION IS REQUIRED, INCLUDING SHOWING PIPE FOR A MINIMUM OF 5 FEET BEYOND JOINTS ON BOTH SIDES OF CUT-IN CONNECTION (**TV INSPECT FROM NEAREST MANHOLE OR MAINLIN CLEANOUT**).
6. A FOLLOWUP WARRANTY TV INSPECTION OF CONNECTION IS REQUIRED NEAR END OF WARRANTY PERIOD, BUT DURING THE FIRST WINTER AFTER INSTALLATION. ANY SETTLEMENT OR LEAKAGE REVEALED SHALL BE CORRECTED BY THE CONTRACTOR AT NO COST TO THE CITY.

LAST REVISION DATE: SEPT 2025	01
<b>LATERAL CUT-IN CONNECTION AT EXISTING SS OR SD MAINS TOO SMALL FOR DTL 419</b> (NTS)	
NOSD, OR	DETAIL NO. 415A

CLEANOUT COVERS: ALL SEWER CLEANOUT LIDS TO READ "SEWER"  
 ALL STORM CLEANOUT LIDS TO READ "STORM" OR "C/O".

1. NON-TRAFFIC AREAS:

CARSON MODEL 910 T-COVER OR EQUAL (GREEN FOR SEWER, GREY FOR STORM).

2. TRAFFIC AREAS, INCLUDING DRIVEWAYS:

8" X 4" CAST IRON FRAME & COVER, OLYMPIC M1007 OR EQUAL.

8" X 6" CAST IRON FRAME & COVER, OLYMPIC M1018 OR EQUAL.

(FOR CI CLEANOUTS IN UNPAVED AREAS, SET IN 6" THICK CONCRETE PAD)

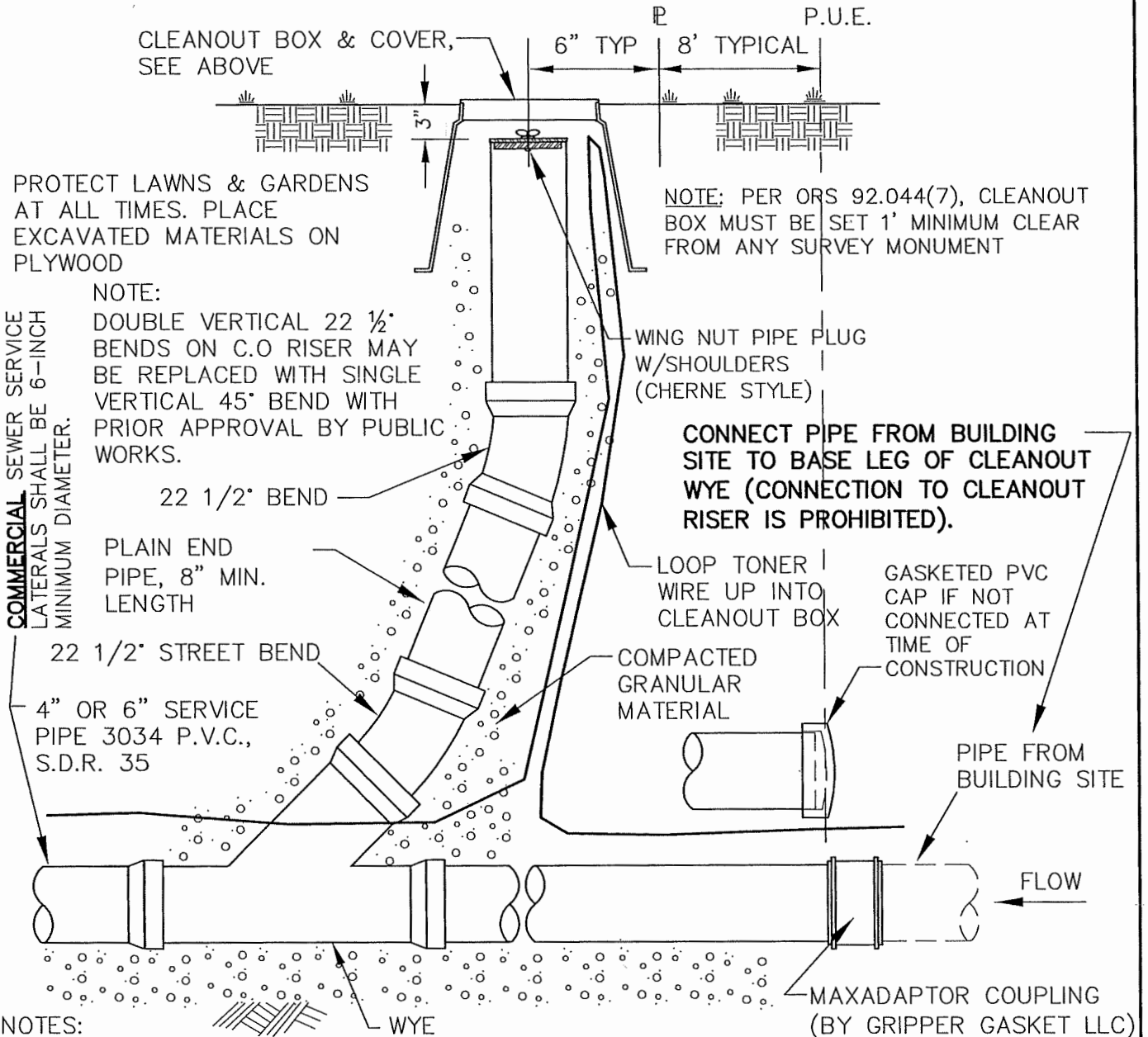

PROTECT LAWNS & GARDENS AT ALL TIMES. PLACE EXCAVATED MATERIALS ON PLYWOOD

NOTE: PER ORS 92.044(7), CLEANOUT BOX MUST BE SET 1' MINIMUM CLEAR FROM ANY SURVEY MONUMENT

NOTE:  
 DOUBLE VERTICAL 22 1/2° BENDS ON C.O RISER MAY BE REPLACED WITH SINGLE VERTICAL 45° BEND WITH PRIOR APPROVAL BY PUBLIC WORKS.

COMMERCIAL SEWER SERVICE  
 LATERALS SHALL BE 6-INCH  
 MINIMUM DIAMETER.

CONNECT PIPE FROM BUILDING SITE TO BASE LEG OF CLEANOUT WYE (CONNECTION TO CLEANOUT RISER IS PROHIBITED).

GASKETED PVC CAP IF NOT CONNECTED AT TIME OF CONSTRUCTION

NOTES:

- CLEANOUT RISER SHALL BE SAME SIZE AND MATERIAL AS LATERAL PIPE.
- PROVIDE CONCRETE PAD FOR CLEANOUTS LOCATED IN UNPAVED DRIVEWAYS OR TRAFFIC AREAS (6" THICK PAD TO BE 6" LARGER THAN CLEANOUT BOX FRAME).
- CLEANOUT PIPE SHALL BE LEFT A MINIMUM OF 18" ABOVE EXISTING GRADE UNTIL ALL CURBING IS INSTALLED AND ALL PRIVATE UTILITY TRENCHES ARE BACKFILLED. CLEANOUTS SHALL THEN BE SET NO MORE THAN 6" BELOW FINISH GRADE, AND CLEANOUT BOXES SET FLUSH WITH FINISH GRADE.

LAST REVISION DATE:

FEB 2024

COPYRIGHT 1996  
 WESTECH ENGINEERING, INC.

STANDARD SERVICE  
 LATERAL CLEANOUT  
 (SEWER)

(NTS)

NOSD, OR

DETAIL NO.

416

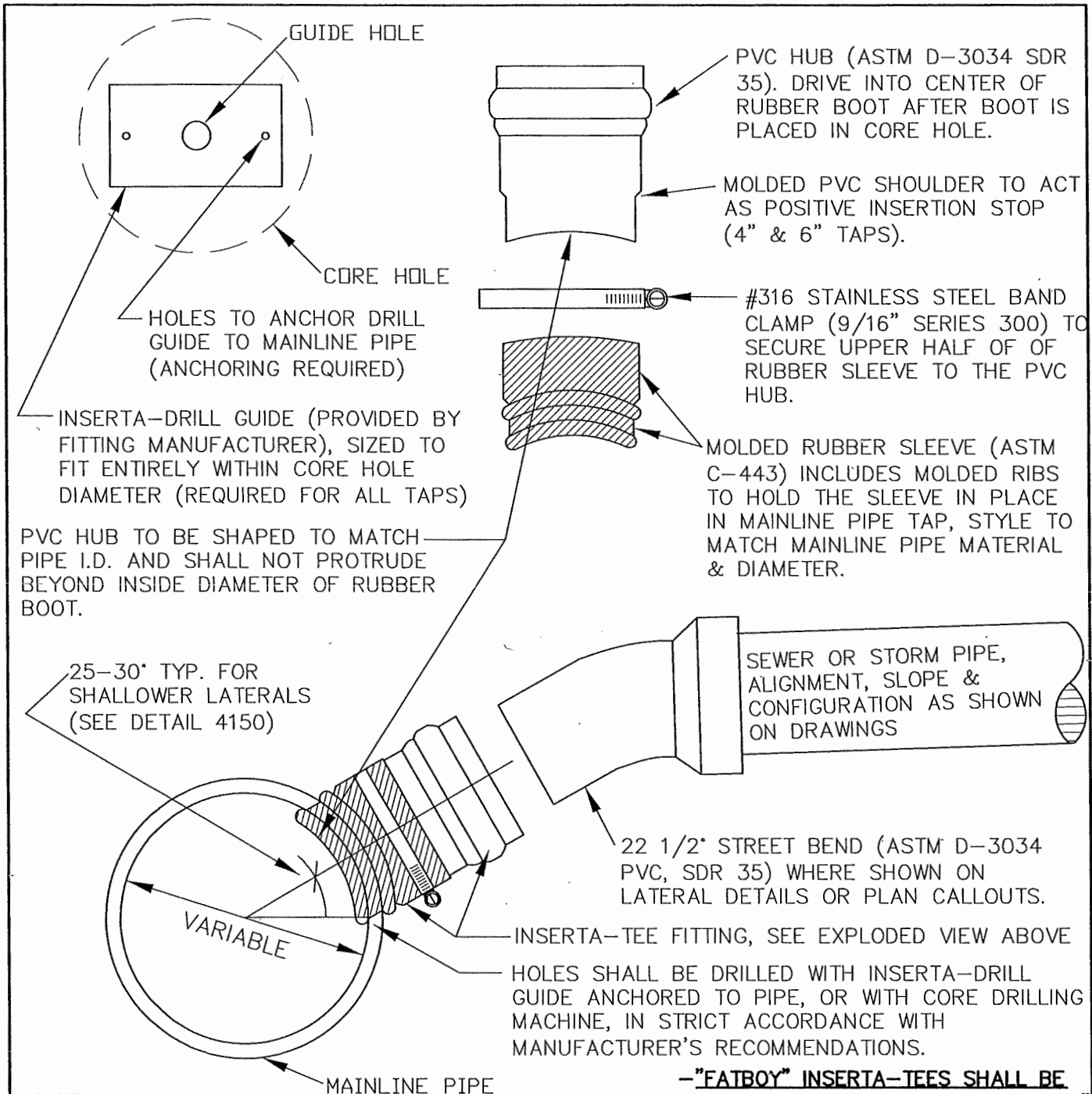

NOTES:

1. MAXIMUM LATERAL SIZE - MAX TAP SIZE SHALL BE 2 NOMINAL PIPE SIZES SMALLER THAN THE MAINLINE PIPE (IE. 4" ON 8", 6" ON 10", ETC.).
2. EXISTING SANITARY SEWERS - INSERTA-TEES ALLOWED ON EXISTING PVC OR DUCTILE IRON SEWER MAINS. USE ON OTHER PIPE TYPES IS SUBJECT TO CITY APPROVAL AND ACCEPTABLE PIPE CONDITION.
3. EXISTING STORM DRAINS - INSERTA-TEES ALLOWED ON ALL PIPE TYPES, SUBJECT TO CITY APPROVAL AND ACCEPTABLE PIPE CONDITION.
4. NEW MAINLINES - MANUFACTURED FITTINGS (PER DETAIL 415) SHALL BE USED FOR CONNECTION ON ALL NEW SEWER AND STORM MAINLINES.
5. THE TAP SHALL NOT BE MADE EXCEPT IN THE PRESENCE OF A CITY INSPECTOR; NOR SHALL ANY CONNECTION BE MADE WITHOUT PRIOR CITY APPROVAL.
6. CENTERLINE OF TAP SHALL BE ABOVE SPRINGLINE.

**"FATBOY" INSERTA-TEES SHALL BE USED FOR ALL S.S. TAPS, AND FOR 4" TAPS ON EXTG 8" STORM DRAIN PIPE. -TV INSPECTION & 95% MANDREL TESTING (AT TAP) MAY BE REQUIRED AFTER CONNECTION AT DISCRETION OF PUBLIC WORKS DIRECTOR.**

LAST REVISION DATE:	JO #
OCT 2025	STANDARD
<b>FATBOY INSERTA-TEE CONN. TO EXISTING SEWER OR STORM DRAIN</b>	
(NTS)	
NOSD, OR	DETAIL NO. 419

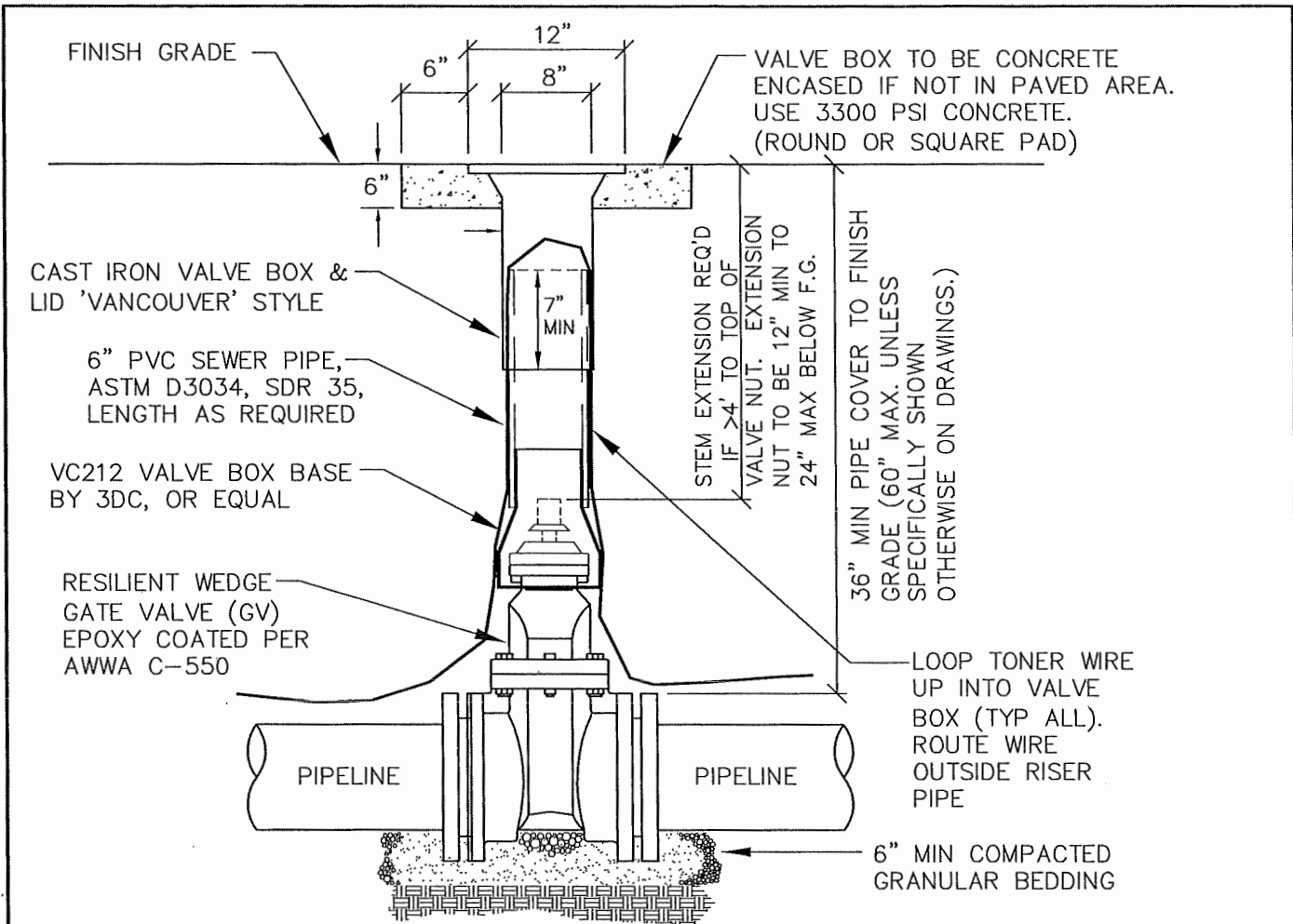

AFTER PAVING OR CONC PAD PLACEMENT, REMOVE LID & GRIND NOTCH IN VB FRAME, 1/8" WIDE x 1/8" DEEP, SHOWING DIRECTION OF FLOW THROUGH VALVE (BOTH SIDES)

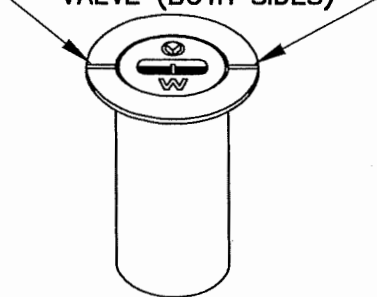

VANCOUVER '910' STYLE  
18" TALL VALVE BOX

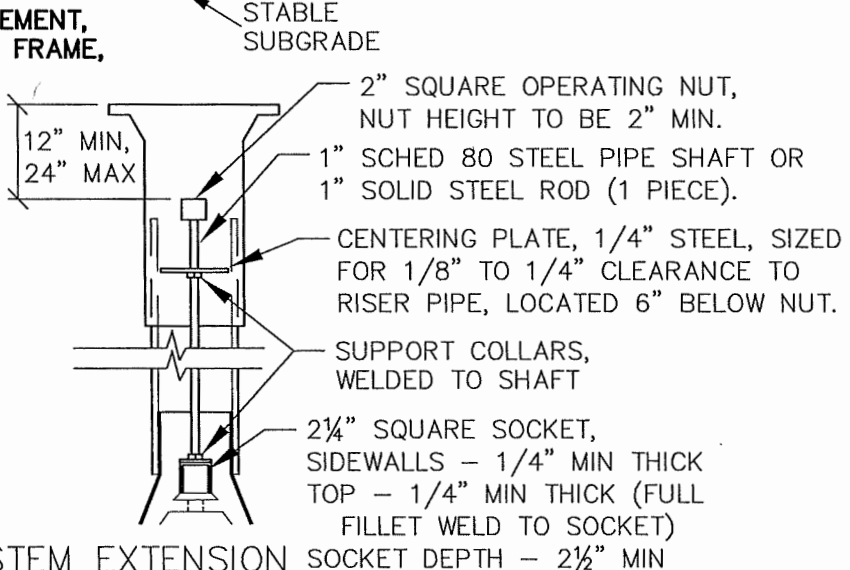

STEM EXTENSION

NOTES:

1. DI BODY GV SHALL CONFORM TO AWWA C-509 OR C-515.
2. VALVE BOXES SHALL BE PLUMB AND CENTERED DIRECTLY OVER THE VALVE NUT, INSTALLED ON VALVE BOX BASE AS SHOWN.
3. VALVE BOX TOP SHALL BE ADJUSTED TO FINISHED GRADE.
4. PVC SHALL BE ONE CONTINUOUS PIECE, NO BELLS OR COUPLERS.
5. VALVE BOX LIDS ON PRESSURE SEWERS TO READ "S" OR "SEWER".
6. COMPLETELY CLEAN OUT ALL VALVE BOX COVER PICKHOLES PRIOR TO REQUESTING FINAL INSPECTION.

LAST REVISION DATE: JULY 2024	JO # STANDARD
<b>GATE VALVE AND VALVE BOX DETAIL</b>	
(NTS)	
NOSD, OR	DETAIL NO. 501

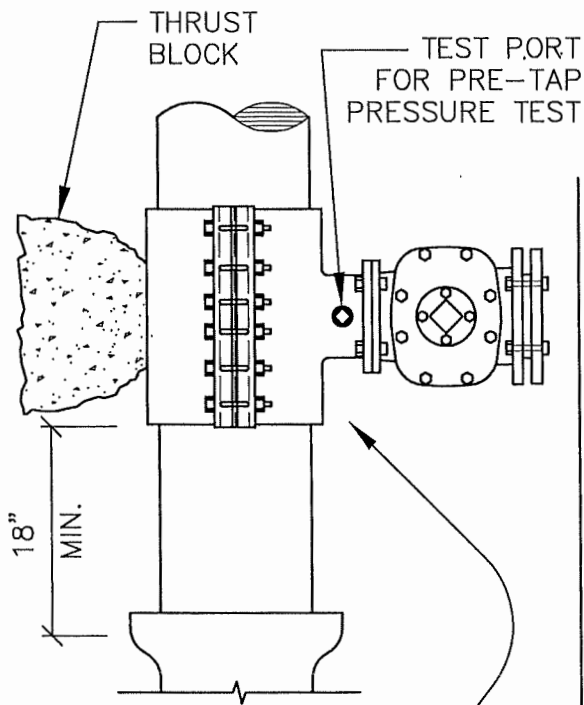

ROMAC SST/SSTIII, MUELLER H304,  
JCM MODEL 432 OR APPROVED EQUAL  
(STAINLESS STEEL SLEEVE AND STAINLESS  
STEEL FLANGE)

TOP VIEW

STD. VALVE BOX  
(VANCOUVER '910'  
STYLE) W/VC212 VB  
BASE & PVC RISER

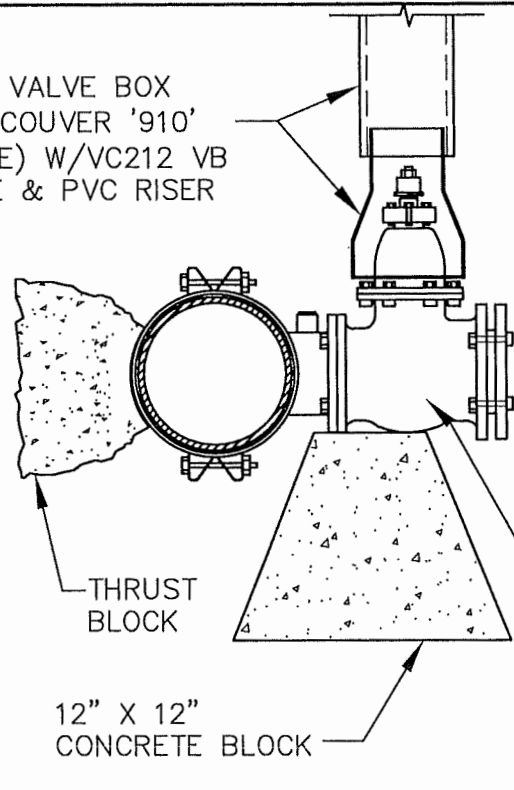

12" X 12"  
CONCRETE BLOCK

THRUST  
BLOCK

RESILIENT WEDGE GATE VALVE  
(FL x MJ UNLESS OTHERWISE  
NOTED ON PLANS)

SIDE VIEW

**NOTES:**

1. WATER MAIN SHALL BE CLEANED & SPRAYED WITH CHLORINE SOLUTION IN TAP AREA BEFORE ATTACHING SLEEVE.
2. TAPPING SLEEVE SHALL BE ALL STAINLESS STEEL WITH FULL PERIMETER GASKET.
3. TAPPING VALVE SHALL BE EPOXY COATED PER AWWA C-550.
4. **PRE-TAP PRESSURE TEST.** SLEEVE AND VALVE SHALL BE PRESSURE TESTED BEFORE MAKING TAP. PRESSURE TEST AND TAP SHALL BE MADE IN THE PRESENCE OF AN AUTHORIZED WATER SYSTEM REPRESENTATIVE.
5. APPROVED TAPPING MACHINE SHALL BE USED TO MAKE TAP.
6. 3/4" GRANULAR BACKFILL SHALL BE PLACED AND COMPACTED TO 92% OF MAXIMUM DENSITY AS DETERMINED BY AASHTO T-180.
7. THRUST BLOCKING PER DETAIL 510.
8. TAP SHALL BE MADE NO CLOSER THAN 18" FROM THE NEAREST JOINT.
9. **SLEEVE AND VALVE SHALL BE WRAPPED WITH 8 MIL PLASTIC PRIOR TO CONCRETE PLACEMENT.**
10. CONCRETE BLOCK(S) SHALL COMPLETELY SUPPORT TAPPING TEE AND VALVE.
11. CONTRACTOR SHALL COORDINATE ALL TAPS WITH CITY AND PERFORM ALL TAPS WITH CO-OP STAFF PRESENT.
12. ALL TAPPING EQUIPMENT (AND ANY TOOL COMING IN CONTACT WITH THE PIPE THROUGH THE TAPPING SLEEVE) SHALL BE CHLORINE DISINFECTED WITH A 300 MG/L CHLORINE SOLUTION.

LAST REVISION DATE: SEPT 2018	COPYRIGHT 1998 WESTECH ENGINEERING, INC.
<b>TAPPING TEE AND VALVE</b>	
(NTS)	
NOSD, OR	DETAIL NO. 505

FITTING SIZE (Inches)	TEE, WYE, & ① HYDRANTS	90° BEND ② (STRADDLE BLOCKS REQ'D FOR PLUGGED CROSS OR PLUGGED TEE)	45° BEND ③	22 1/2° BEND ③	11 1/4° BEND ③
2	*	*	*	*	*
4	1.7	2.4	1.3	*	*
6	3.7	5.3	2.9	1.5	*
8	6.7	9.5	5.1	2.7	1.3
10	10.5	14.8	8	4.1	2
12	15.1	21.3	11.6	5.9	2.9
16	26.8	37.9	20.5	10.4	5.2
18	33.9	47.9	25.9	12.8	6.7
LARGER	* *	* *	* *	* *	* *
BEARING AREA OF THRUST BLOCKS (sq. ft.)					

- \* BLOCK TO UNDISTURBED TRENCH WALLS
- \* \* THRUST BLOCKS FOR PIPES LARGER THAN 18" WILL BE INDIVIDUALLY DESIGNED BY THE ENGINEER.

**NOTES:**

1. ALL VALUES ARE BASED ON THE FOLLOWING ASSUMPTIONS:  
AVG. PRESSURE = 100 PSI x 2 (safety factor); 1500 PSF SOIL BEARING CAPACITY; NORMAL DISTRIBUTION SYSTEM DESIGN VELOCITY NOT TO EXCEED 5' FPS.
2. **ALL FITTINGS SHALL BE WRAPPED IN PLASTIC PRIOR TO PLACEMENT OF CONCRETE.**
3. BEARING SURFACE OF THRUST BLOCKING SHALL BE AGAINST UNDISTURBED SOIL.
4. TRUCK-MIXED CONCRETE MIX SHALL HAVE A MIN. 28 DAY STRENGTH OF 3300 PSI (5" MAX SLUMP). USE OF HAND-MIXED SACK-CRETE TYPE CONCRETE REQUIRES WRITTEN LOCAL JURISDICTION APPROVAL PRIOR TO USE, AND SHALL BE 4000 PSI MIX, MIXED WITH MIN AMOUNT OF WATER NECESSARY FOR WORKABILITY (5" MAX SLUMP). USE OF DRY SACK-CRETE MIX (BAGS OR LOOSE MIX) IS PROHIBITED FOR PERMANENT THRUST RESTRAINT.
5. ALL PIPE ZONES SHALL BE BACKFILLED WITH GRANULAR BACKFILL AND COMPACTED.
6. IF THRUST BLOCKS ARE APPROVED IN WRITING FOR INSTALLATION IN FRONT OF PLUGGED CROSS OR PLUGGED TEE, EACH SHALL HAVE A #4 REBAR LIFTING LOOP INSTALLED IN TOP TO ALLOW FOR FUTURE TB REMOVAL.
7. VERTICAL THRUST RESTRAINT - TYPICALLY USE STRADDLE BLOCK PER DETAIL 511 (RETAINER GLANDS REQUIRED ON ALL ADJACENT MJ JOINTS).
8. STRADDLE BLOCK DETAILS - SEE DETAIL 511.

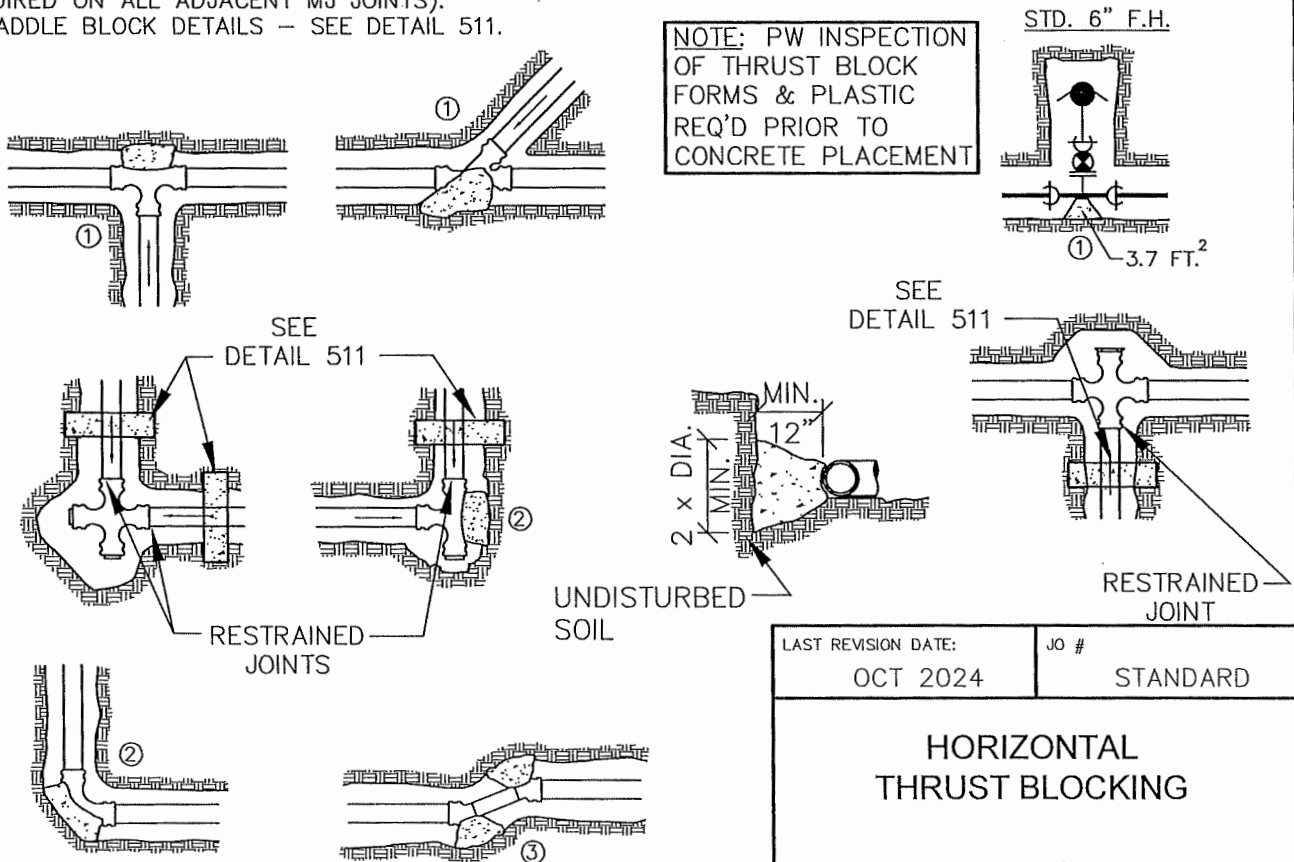

NOTE: PW INSPECTION OF THRUST BLOCK FORMS & PLASTIC REQ'D PRIOR TO CONCRETE PLACEMENT

STD. 6" F.H.

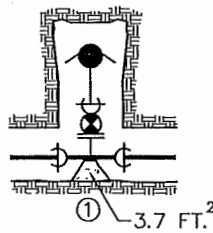

SEE DETAIL 511

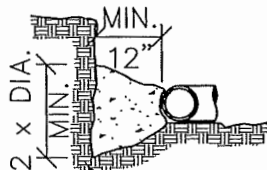

UNDISTURBED SOIL

RESTRAINED JOINT

LAST REVISION DATE: OCT 2024	JO # STANDARD
<b>HORIZONTAL THRUST BLOCKING</b>	
(NTS)	
NOSD, OR	DETAIL NO. 510

## MATERIALS

- ① CONCRETE STRADDLE BLOCK.
- ② -EITHER (2a) ONE SERRATED-LOCK STYLE SPLIT-RING RESTRAINT HARNESS (ROMAC 600 OR EQUAL), OR (2b) TWO RETAINER GLAND WEDGE-STYLE RESTRAINTS, SET OPPOSED (EBBA MEGA-LUG OR EQUAL).
- WEDGE STYLE RESTRAINTS SHALL BE WRAPPED WITH PLASTIC PRIOR TO CONCRETE PLACEMENT.
- ③  $\leq 12"$  PIPE, #4 REBAR @12" O.C. E.W., (3a) INSTALL REBAR EACH SIDE OF RESTRAINT FITTING INSIDE CONCRETE AS SHOWN. (3b) INSTALL 3 MATS OF REBAR FOR PIPE LARGER THAN 12" DIAMETER.
- ④ RETAINER GLAND, ON ADJACENT FITTING.
- ⑤ MJ FITTING, BEND, VALVE OR BLOWOFF.

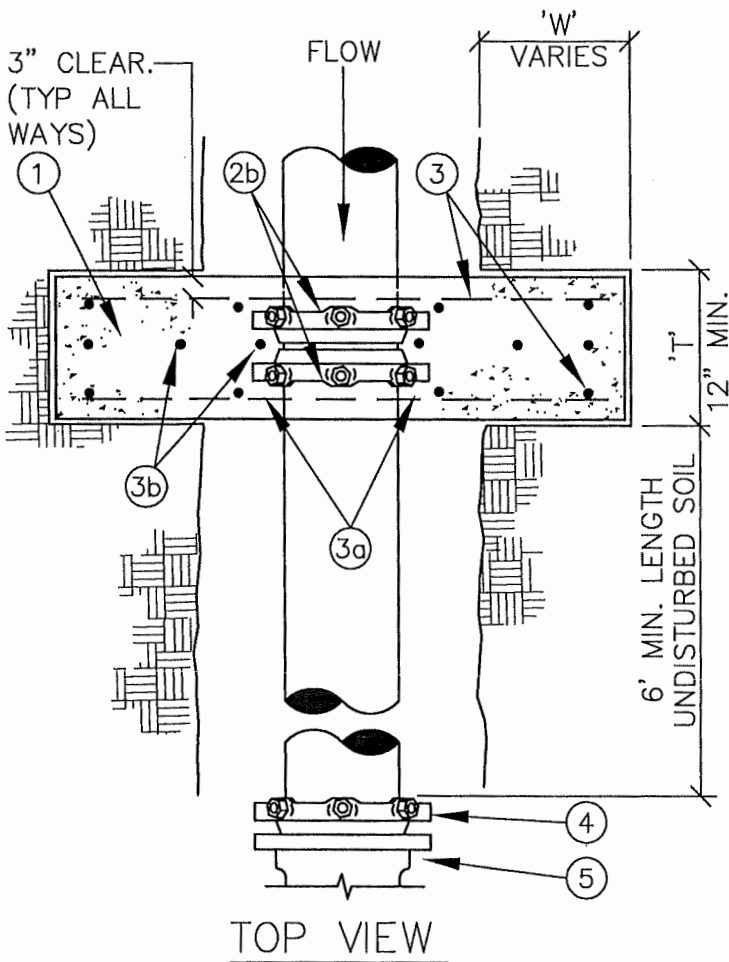

PIPE SIZE	'W'	'D'	'T'
6"	12"	8"	12"
8"	16"	10"	12"
10"	20"	12"	12"
12"	24"	18"	18"
>12"	BY ENGINEER		

## NOTES:

1. STRADDLE BLOCKS FOR >12" PIPE SHALL BE DESIGNED INDIVIDUALLY BY THE ENGINEER AND SHALL BE BASED ON THE FOLLOWING:
  - a.) 200 PSI WATER PRESSURE.
  - b.) SOIL BRG. CAPACITY, STEEL SIZE & SPACING BY THE ENGINEER.
2. BEARING AREA OF BLOCK SHALL BE AGAINST UNDISTURBED SOIL.
3. STRADDLE BLOCK SHALL HAVE A MINIMUM OF 18" COVER.
4. CONCRETE SHALL HAVE A MIN. 28 DAY STRENGTH OF 3300 PSI.

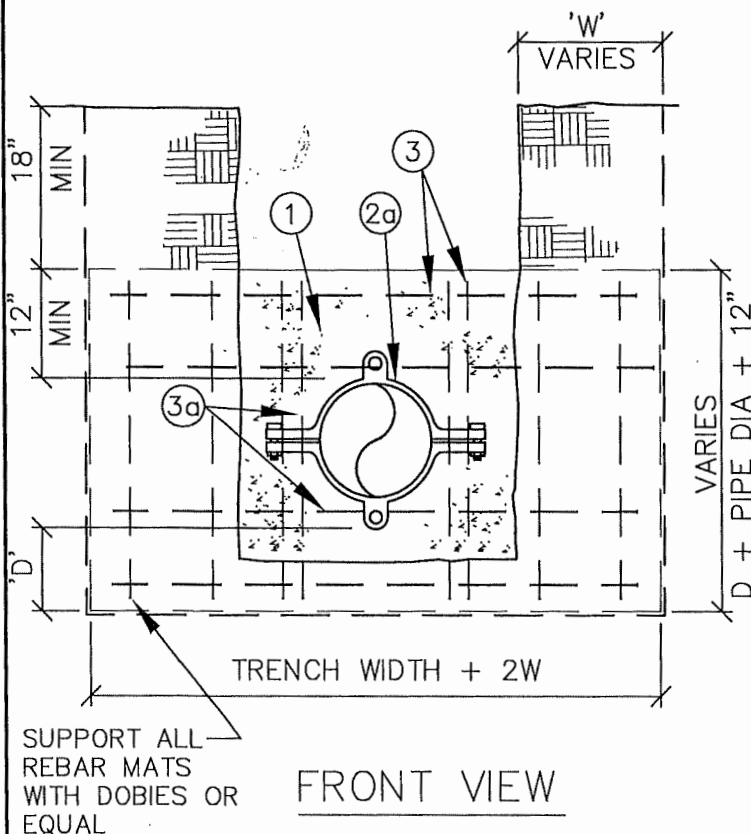

LAST REVISION DATE: DEC 2021	COPYRIGHT 1996 WESTECH ENGINEERING, INC.
STRADDLE BLOCK FOR 12" AND SMALLER PIPE	
(NTS)	
NOSD, OR	DETAIL NO. 511

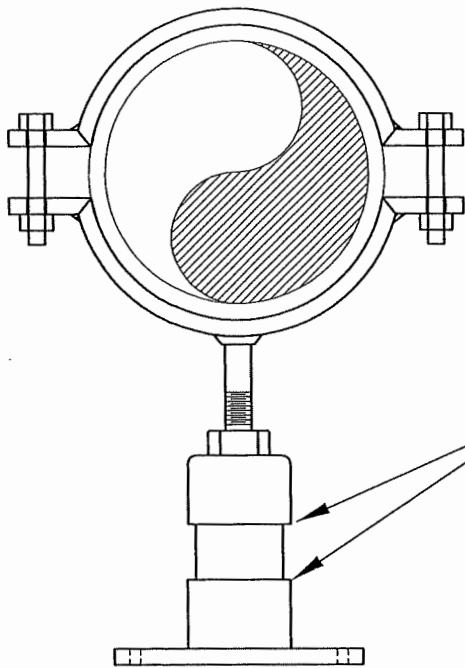

STANDON MODEL C92 ADJUSTABLE PIPE SUPPORT (GALVANIZED STEEL TOP & BASE) OR EQUAL (PROVIDE NEOPRENE LINER FOR STEEL OR PVC PIPE)

WHERE FULLY RESTAINED SUPPORTS ARE SPECIFIED OR NOTED ON THE DRAWING, FILLET TACK WELD SUPPORT PIPE TO BASE AND TOP COLLARS AFTER INSTALLATION (E70XX ELECTRODES FOR WELDS). COAT WELDS WITH HIGH ZINC PAINT (2 COATS), TYP ALL.

**FULL CIRCLE CLAMP STYLE SUPPORT**

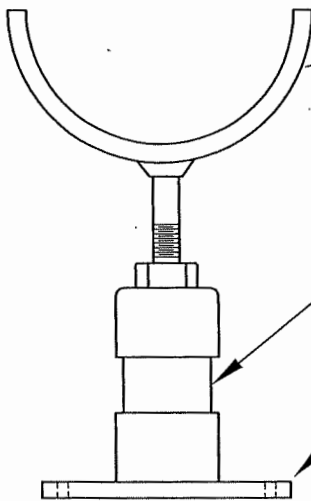

STANDON MODEL S92 ADJUSTABLE PIPE SUPPORT (GALVANIZED STEEL TOP & BASE) OR EQUAL (PROVIDE NEOPRENE LINER FOR STEEL OR PVC PIPE)

SCHEDULE 40 GALVANIZED STEEL PIPE (TYP ALL STYLES, LENGTH AS REQUIRED), DIA. PER MANUFACTURER'S RECOMMENDATIONS

INSTALL (4) EACH 1/2" X 4" STAINLESS STEEL CONCRETE ANCHORS OR STUD ANCHORS WITH NUTS (TYP ALL STYLES).

**SADDLE STYLE SUPPORT**

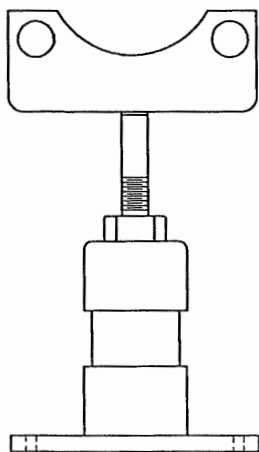

STANDON MODEL C89 ADJUSTABLE PIPE SUPPORT (GALVANIZED STEEL TOP & BASE) OR EQUAL

12" SQUARE CONCRETE PIER BLOCK FOR SUPPORT IN AREAS WITHOUT SLAB OR PAVEMENT. ANCHOR BOLTS/STUDS AS NOTED ABOVE.

**FLANGE STYLE SUPPORT**

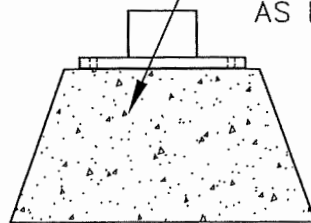

**BASE IN AREA W/OUT HARD SURFACE**

LAST REVISION DATE: JAN 2018	COPYRIGHT 2018 WESTECH ENGINEERING, INC.
<b>GALVANIZED PIPE SUPPORTS W/GALVANIZED EXT. PIPE (FLANGE, SADDLE &amp; CLAMP) (NTS)</b>	
NOSD, OR	DETAIL NO. 529

# MANHOLE VACUUM TEST REPORT

Project Location: (City)	Project Name:
Inspector: (Print)	Date: (Separate Report Required for Each Test Session)
Testing Company: (Name & Phone #)	

Manhole No.	Manhole Diameter (inch)	Manhole Depth (ft)	Surface Restoration Complete?	Time Required <sup>3</sup> (sec)	Time to Drop from 10" Hg to 9" Hg (sec)	Results	Comments
			Yes / No			Pass / Fail	
			Yes / No			Pass / Fail	
			Yes / No			Pass / Fail	
			Yes / No			Pass / Fail	
			Yes / No			Pass / Fail	
			Yes / No			Pass / Fail	
			Yes / No			Pass / Fail	
			Yes / No			Pass / Fail	
			Yes / No			Pass / Fail	
			Yes / No			Pass / Fail	

1. All adjacent surface restoration shall be completed prior to conducting manhole acceptance tests, including finish paving and final adjustments to grade. Any test conducted prior to completion of surface restoration shall be considered informal, and will not count for acceptance.
2. The vacuum test head seal shall be inflated in accordance with the manufacturer's recommendations, but in all cases the grade rings and casting shall be included in the test. A vacuum of 10-inches of mercury shall be drawn and the vacuum pump shut off. With the valves closed, the time shall be measured for the vacuum to drop to 9-inches.
3. The manhole shall pass if the time for the vacuum reading to drop to 9-inches meets or exceeds the values indicated on the following table. Times for deeper depths as required by the NOSD Engineer. Note: Visible groundwater infiltration or leakage constitutes a failed test.

<b>REQUIRED MANHOLE VACUUM TEST TIMES</b>			
Manhole Depth (feet)	Required Time (sec)		
	48-inch diameter	60-inch diameter	72-inch diameter
8	20	26	33
10	25	33	41
12	30	39	49
14	35	46	57
18	40	52	65
20	45	59	73
22	50	65	81

# SANITARY SEWER AIR TEST REPORT

Project Location:	Project Name:
Inspector: (Print)	Date: (Separate Report Required for Each Test Session)
TV Inspection Required? Yes / No	Mandrel Testing Completed? Date Completed or Scheduled:
Verify that all sewer laterals and associated cleanouts installed and cleanout risers are visible at or above finish grade? Yes / No	Verify that all franchise utilities which cross sewer laterals have been installed and trenches backfilled? Yes / No

Station (& Manhole #)		Main/ Lateral	Size & Material	Total Length (ft)	C <sup>1</sup>	K <sup>1</sup>	Test Time (Seconds) for Pressure Drop Shown (psi)			Comments
							Required <sup>2</sup>	4.0 - 3.5	3.5 - 2.5	
From	To									
		Main								Pass / Fail
		Laterals								
		Totals								
		Main								Pass / Fail
		Laterals								
		Totals								
		Main								Pass / Fail
		Laterals								
		Totals								
		Main								Pass / Fail
		Laterals								
		Totals								

<sup>1</sup> For C and K values, see table and formulas on reverse side.  
<sup>2</sup> For total C ≤ 1.0, test time (seconds) required = 2 times K  
For total C > 1.0, test time (seconds) required = 2 times (K/C)

**TEST PROCEDURE**

1. Add air slowly to the portion of the pipe installation under test until the internal air pressure is raised to 4.0 psig (or higher pressure as required to address groundwater). Increase the test pressure by 0.433 psi for each foot of average ground water depth over the exterior crown of the pipe under test, with the maximum test pressure not to exceed 9.0 psi.
2. Add air slowly until the internal air pressure is raised to 4.0 psig (or higher pressure as required due to groundwater).
3. After required test pressure is reached, allow 2-minutes minimum for air temperature to stabilize, adding only the amount of air required to maintain pressure.
4. After the temperature stabilization period, disconnect the air supply.
5. Record the time required for the internal air pressure to drop from 3.5 psi (or higher as required due to groundwater backpressure) to 2.5 psi (or higher as required due to groundwater backpressure). If this time exceeds the required time (or if there is less than 1.0 psi pressure drop), the test is successful.

**ACCEPTANCE:** The tested sewer section shall be considered acceptable if the pressure drop during the test time is less than 1.0 psi from the starting pressure.

### SEWER AIR TEST C AND K VALUES

Pipe Size (inch)	C-Value <sup>1</sup> per foot length	K-Value <sup>2</sup> per foot length
4	0.00155	0.176
6	0.00233	0.396
8	0.00311	0.704
10	0.00388	1.100
12	0.00466	1.584
15	0.00582	2.475
18	0.00699	3.564
21	0.00815	4.851

<sup>1</sup> C = 0.0003882dL      Where d = diameter (inches)  
<sup>2</sup> K = 0.011d<sup>2</sup>L      L = Length (ft)

Example:

Air Test a system consisting of two mainline segments as follows:

Segment 1: 395 feet of 8-inch mainline, 100 feet of 4-inch laterals, and 35 feet of 6 inch laterals.

Segment 2: 200 feet of 8-inch mainline, 30 feet of 4-inch laterals, and 20 feet of 6 inch laterals.

Station (& Manhole #)		Main/ Lateral	Size & Material	Total Length (ft)	C <sup>1</sup>	K <sup>1</sup>	Test Time (Seconds) for Pressure Drop Shown (psi)			Comments
							Required <sup>2</sup>	4.0 - 3.5	3.5 - 2.5	
From	To									
0+00 MH A1	3+95 MH A2	Main	8" PVC	395	1.227	278.1	310/1.46= 212			Pass / Fail
		Laterals	4" PVC	100	0.155	17.6				
			6" PVC	35	0.082	13.86				
		Totals			1.464	309.54				
3+95 MH A2	5+95 MH A3	Main	8" PVC	200	0.621	140.8	2*154= 308 sec			Pass / Fail
		Laterals	4" PVC	20	0.047	5.28				
			6" PVC	30	0.047	7.92				
		Totals			0.714	154.0				

Note: For total C ≤ 1.0, test time (seconds) required = 2 times K  
 For total C > 1.0, test time (seconds) required = 2 times (K/C)

The tested sewer section shall be considered acceptable when tested as described herein if the section under test does not loose air at a rate greater than 0.0015 cfm per square foot of internal sewer surface.



# GRAVITY SEWER PIPELINE TV INSPECTION REPORT (Sample) Page \_\_\_ of \_\_\_

Date:	Client: City:				Basin No.	
Technician:	Inspector:	Weather:	Cleaned By:		Report No.	Tape No.
From M.H. #: Street:	Pipe Dia. (in)	Joint Length (ft)	Section Length (ft)	Joint Type:	Pipe Material	To M.H. #: Street:
<b>PIPELINE DATA;</b>						
Cleanliness: _____	Footage	Problem Code	Comments	I/I (gpm)		
Alignment: _____						
Grade: _____			s			
Age: _____						
%Est. Leaking Joints: _____						
Other: _____						
<b>PROBLEM CODE LEGEND:</b>						
BP = Broken Pipe						
CC = Circumferential Crack						
LC = Longitudinal Crack						
G = Break in Grade						
L = Leak						
PJ = Pulled Joint						
PT = Protruding Tap						
ST = Service Tap						
SL = Service Left						
SR = Service Right						
RT = Roots						
- Unpassable						
<b>PIPE MATERIAL LEGEND:</b>						
AC = Asbestos Cement						
CIP = Cast Iron Pipe						
C(M) = Conc., Mortar Joint						
C(R) = Conc., Rubr. Gasket Jnt						
DI = Ductile Iron Pipe						
PVC = Polyvinylchloride Pipe						
TC = Terra Cotta						
VC = Vitrified Clay						
<b>TURNAROUND:</b>						
Requested (Date/time): _____						
Authorized (Date/time): _____						

**Gravity Sewer TV Inspection.** Upon completion of all sewer construction, testing and repair (including channeling of sanitary sewer manholes), the Contractor shall conduct a color TV acceptance inspection of all mainlines in accordance with OSSC (ODOT/APWA) 445.74 to determine compliance with grade requirements of OSSC (ODOT/APWA) 445.40.b (no deviation greater than 1/32-inch per inch of pipe diameter [1/2-inch max for pipes >16-inch diameter], AND no reverse sloping pipe), AND to verify pipelines are adequately cleaned. The TV inspection shall be conducted by an approved technical service, using a track or wheel propelled self-leveling auto-focus pan-head camera which is equipped to make audio-visual recordings of the TV inspections on a USB storage device. Unless otherwise required by the agency with jurisdiction, a standard 1-inch diameter ball shall be suspended in front of the camera during the inspection (with the ball in contact with the pipe invert) to determine the depth of any standing water. Sufficient water to reveal low areas or reverse grades shall be discharged into the pipe immediately prior to initiation of the TV inspection. The USB storage device and written report (or download link and pdf report) shall be delivered to the NOSD Engineer.





## OREGON ADMINISTRATIVE RULES 340-052-0040

### Responsibility of Treatment Works Owners, Design Engineers and Developers After Approval of Plans for (Domestic) Sewage Projects

- (1) Construction of all projects must be in accordance with the project plans and specifications approved by the Department. No substantial change in or deviation from such plans and specifications shall be made without the prior written approval of the Department, which shall make the final determination whether or not a change or deviation is in fact substantial.
- (2) The owner of the sewerage system (generally a municipality) as recipient of any construction work on its system has a vested responsibility to review and approve project plans prior to the start of construction. Department approval of plans under these rules does not preclude the right and responsibility of review and approval by the owner. The owner may adopt more stringent construction standards and impose special conditions for sewer use, service connection, and related activities. Department approval of plans in such cases is contingent upon similar approval by the owner. Submittal of plans to the Department through the owner and prior approval of plans by the owner is encouraged.
- (3) Inspection and certification of proper construction shall be governed by the following provisions:
  - (a) The construction of all sewerage projects shall be under the supervision of and shall be thoroughly inspected by the design engineer or his authorized representative, unless relieved under subsection (b) of this section. At the completion of the project, he shall certify in writing to the owner and the Department that such construction was inspected by him and found to be in accordance with the plans and specifications, including any changes therein approved by the Department. Nothing in the foregoing exempts an owner from monitoring the project for conformance to requirements and performing supplementary inspections or prevents an owner's qualified staff from assuming responsibility for inspection and certification;
  - (b) If the design engineer is to have no further involvement or have limited involvement with the project after obtaining Department approval of plans, he must so notify the Department, the owner, and the developer upon submittal of plans or immediately upon being disassociated or limited in control over materials or workmanship within the project. (Nothing precludes either the owner or the developer from giving such notice if this is more appropriate). Thereupon, if the project is to continue on to construction, the owner shall assume necessary responsibility for satisfactory construction of the project in accordance with the approved plans. He shall employ or apply such construction engineering/inspection services as appropriate for the project. The owner shall thereupon certify in accordance with subsection (a) of this section. No project shall proceed to construction without adequate and capable construction engineering/inspection services. (This assumption of construction engineering/inspection services responsibility by the owner does not necessarily relieve the design engineer of design responsibility);
  - (c) Sewerage system integrity and watertightness is the system owner's ultimate responsibility. He shall monitor all private sewer construction and control all common sewer construction in the sewerage system to the extent necessary to this end.
- (4) An appropriate final operation and maintenance manual, approved by the Department shall be prepared and submitted to the owner by the design engineer for all treatment works, disposal systems, and list stations prior to start up of such facilities.

Stat. Auth.: ORS 454.626, ORS 454.780 & ORS 468.020

Stats. Implemented: ORS 468B.055

Hist.: DEQ 3-1981, f. & ef. 2-6-81; DEQ 27-1994, f. & cert. ef. 11-15-94

Page 2 of 2

Revision

May 2024

# PRESSURE SEWER PIPELINE, PRESSURE TEST REPORT

Project Location:	Project Name:	Date:
Inspector: (Print)	<b>Pressure pipeline to be tested.</b> From Station:	To Station:
Verify that all in-line valves are open? Yes / No		
Verify that pressure gauge is mounted at high point of line to be tested? Yes / No If no, correct for elevation difference ( <i>ie. add 0.433 psi per foot elevation difference</i> ).		
System Static Pressure (psi):	Starting Pressure (psi): <i>(greater of 150 psi or 1.5 times static)</i>	Ending Pressure (psi):
Pipe Lengths & $\phi$ 's:	Starting Time:	Ending Time <i>(2 hours minimum)</i> :
Volume Required to Reach Initial Test Pressure (gal):	Allowable Leakage (gal): <i>(2 times table or calculated value below)</i>	Measured Leakage (gal):
<b>TEST RESULTS:</b> Pass / Fail		

**ALLOWABLE LEAKAGE PER 1,000 FEET OF PIPELINE - gph** (*NOTE: double the values from table below for a 2 hour test*)

Test Pressure <i>psi</i>	NOMINAL PIPE DIAMETER - in.									
	3	4	6	8	10	12	14	16	18	20
200	0.32	0.43	0.64	0.85	1.06	1.28	1.48	1.70	1.91	2.12
175	0.30	0.40	0.59	0.80	0.99	1.19	1.39	1.59	1.79	1.98
150	0.28	0.37	0.55	0.74	0.92	1.10	1.29	1.47	1.66	1.84

If the pipeline under test contains various diameters, the allowable leakage shall be the sum of the allowable leakage for each size.  
No additional leakage allowance will be given for fire hydrant assemblies or valves.

**Sample:** 700' 8" and 55' 6" pipe.  $\rightarrow \rightarrow 0.74 \text{ gph} / 1,000' * 700' + (0.55 \text{ gph} / 1,000' * 55') = 0.548 \text{ gph} * 2 \text{ hours} = \sim 1.1 \text{ gallon allowable leakage loss.}$

Allowable leakage based on:  $L = SD(P)^{1/2} / 133,200$

Where:

L = allowable leakage, in gallons per hour      D = nominal diameter of the pipe, in inches  
S = length of pipe tested, in feet                  P = test pressure during the leakage test, in psig

Regardless of leakage, maximum pressure drop during test period shall not exceed 5 psi over the 2 hour test period.

**Any visible leaks shall be repaired regardless of the whether or not the pipeline meets leakage allowance.**

## TEST PROCEDURE

1. Apply hydrostatic pressure by pumping water from an auxiliary supply basin. Accurately determine the amount of water required to reach the initial test pressure by refilling the supply basin with a calibrated container following pressurization of pipeline.
2. Monitor test pressure for 2 hour period.
3. At the completion of the test period, re-pressurize the pipeline by pumping water from the auxiliary supply basin (*mark the water surface level in the auxiliary supply basin prior to re-pressurization*).
4. **Accurately determine the amount of water required to reach the test pressure by refilling the supply basin to the marked line with a calibrated container following re-pressurization of pipeline.** If the measured leakage is less than the allowable leakage, the test is successful.

Reference: For HDPE pipelines, additional pipe relaxation times are required after pressurization, per NOSD standards & direction.

EXIST. PUBLIC ROAD OR APPROVED ACCESS POINT

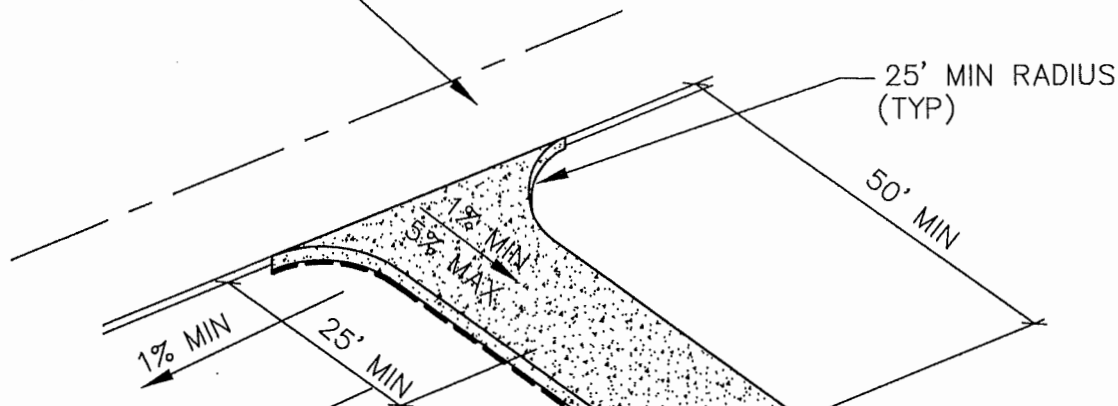

GRADE 25' MINIMUM OF CONSTRUCTION ENTRANCE TO DRAIN AWAY FROM STREET. GRADE ADJACENT AREAS TO DRAIN AWAY FROM TEMPORARY CONSTRUCTION ENTRANCE.

PLACE 3"-6" GRANULAR MATERIAL OVER 8-OUNCE NON-WOVEN GEOTEXTILE FABRIC AS FOLLOWS:

DRY WEATHER ACCESS

14-INCH MIN. DEPTH OVER COMPACTED SUBGRADE & FABRIC

WET WEATHER ACCESS

24-INCH MIN. DEPTH OVER UNDISTURBED SUBGRADE & FABRIC

FULL WIDTH OF PROPOSED STREET OR ACCESS (25' MINIMUM)

CONSTRUCTION NOTES:

1. THE AREA OF THE CONSTRUCTION ENTRANCE SHALL BE STRIPPED OF ALL TOPSOIL, VEGETATION, ROOTS, AND OTHER NON-COMPACTABLE MATERIAL.
2. SUBGRADE SHALL BE COMPACTED AND PROOFROLLED PRIOR TO PLACEMENT OF GRANULAR MATERIAL. FAILURE TO PASS PROOFROLL WILL REQUIRE USE OF WET WEATHER SECTION.
3. FAILURE OR PUMPING OF THE DRY WEATHER SECTION WILL REQUIRE REMOVAL OF THE GRANULAR MATERIAL AND INSTALLATION OF THE WET WEATHER SECTION.

MAINTENANCE NOTES:

1. THE ENTRANCE SHALL BE MAINTAINED IN A CONDITION THAT WILL PREVENT TRACKING OR FLOW OF SEDIMENT ONTO PUBLIC RIGHT-OF-WAY. THIS MAY REQUIRE PERIODIC TOP DRESSING WITH 3"-6" INCH STONE AS CONDITIONS DEMAND, AND REPAIR AND/OR CLEAN-OUT OF STRUCTURES USED TO TRAP SEDIMENT.
2. ALL MATERIALS SPILLED, DROPPED, WASHED OR TRACKED FROM VEHICLES ONTO ROADWAYS OR INTO STORM DRAINS MUST BE REMOVED IMMEDIATELY.
3. ALL TRUCKS TRANSPORTING SATURATED SOILS SHALL BE WELL SEALED. WATER DRIPPAGE FROM TRUCKS MUST BE REDUCED TO 1 GALLON PER HOUR PRIOR TO LEAVING THE SITE.

LAST REVISION DATE: MAY 2013	JO # STANDARD
<b>TEMPORARY CONSTRUCTION ENTRANCE</b> (NTS)	
NOSD, OR	DETAIL NO. 610

SILT FENCE NOTES:

1. BURY BOTTOM OF FILTER FABRIC 6" VERTICALLY BELOW FINISHED GRADE.
2. TRENCH TO BE DUG WITH DITCH-WITCH, BY HAND OR OTHER METHOD AS REQUIRED TO MINIMIZE WIDTH.
3. BACKFILL & COMPACT NATIVE SOIL IN TRENCH AFTER FENCE INSTALLATION.
4. STITCHED LOOPS TO BE INSTALLED TO THE UPHILL SIDE OF THE FENCE.

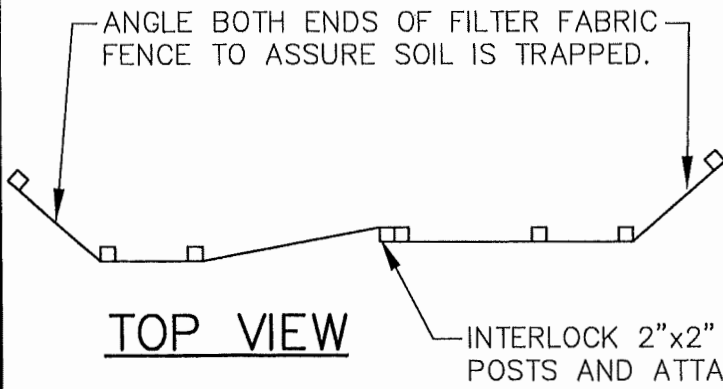

TOP VIEW

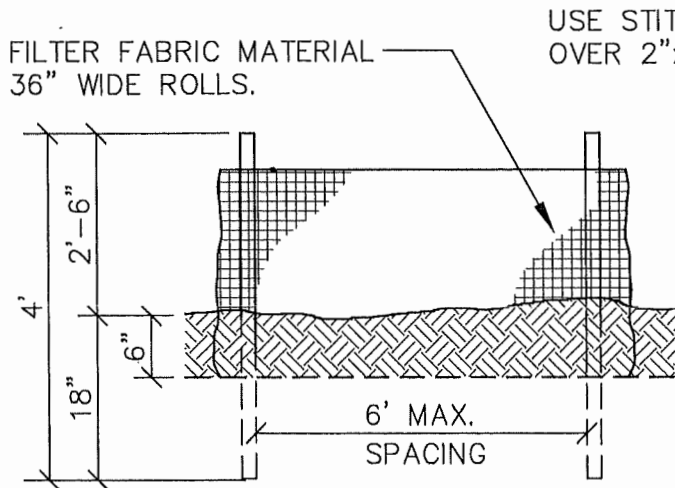

FRONT VIEW

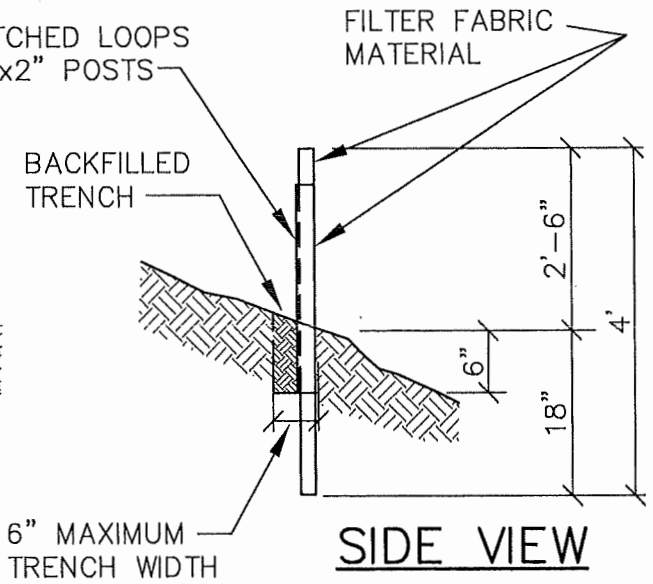

SIDE VIEW

MAINTENANCE NOTES:

1. SEDIMENT BARRIERS SHALL BE MAINTAINED UNTIL UP-SLOPE AREA IS PERMANENTLY STABILIZED.
2. AT NO TIME SHALL MORE THAN ONE FOOT OF SEDIMENT BE ALLOWED TO ACCUMULATE BEHIND SEDIMENT FENCES OR BIOFILTER BAGS.
3. NEW SEDIMENT BARRIERS SHALL BE INSTALLED UPHILL AS REQUIRED TO CONTROL SEDIMENT TRANSPORT.

LAST REVISION DATE: APRIL 2014	JO # STANDARD
SEDIMENT BARRIERS	
(NTS)	
NOSD, OR	DETAIL NO. 611

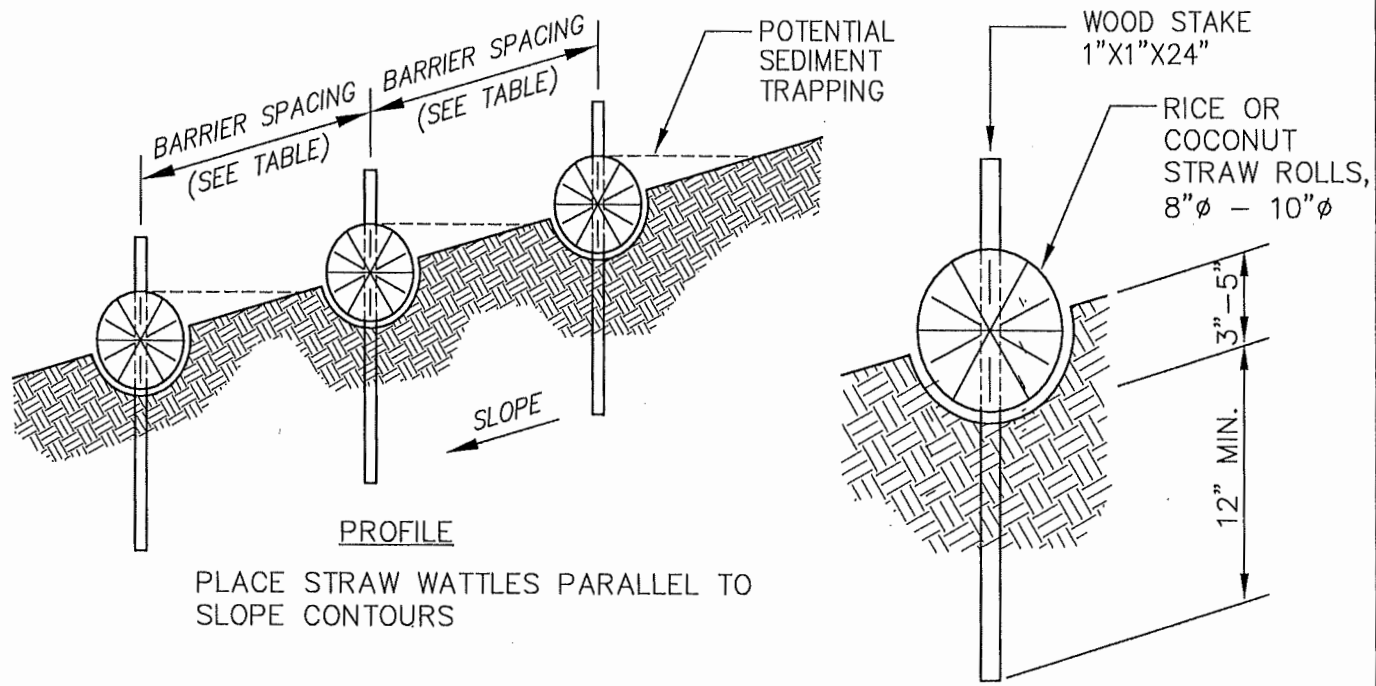

PLACE STRAW WATTLES PARALLEL TO SLOPE CONTOURS

SECTION

STAKE SPACING 4' MAX.

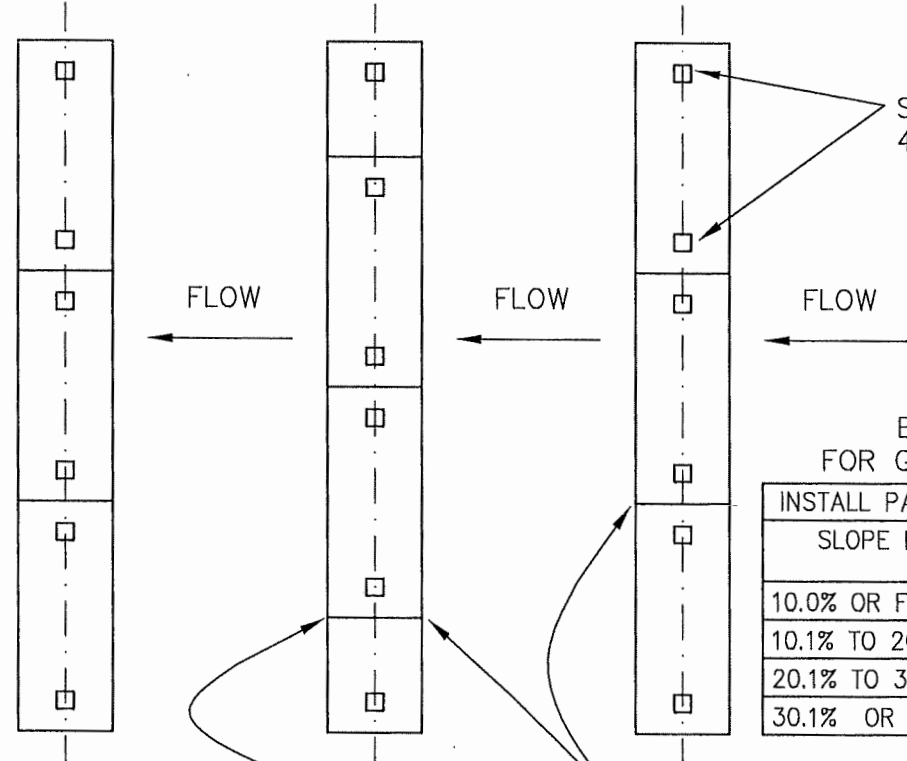

BARRIER SPACING FOR GENERAL APPLICATION

INSTALL PARALLEL TO CONTOURS AS FOLLOWS	
SLOPE RATIO	MAXIMUM SPACING ON SLOPE BETWEEN WATTLES
10.0% OR FLATTER	50' O.C.
10.1% TO 20.0%	25' O.C.
20.1% TO 30.0%	10' O.C.
30.1% OR STEEPER	5' O.C.

TIGHTLY ABUT ADJACENT WATTLES

PLAN

STAGGER JOINTS

NOTES:

1. ALL MATERIAL SHALL CONFORM TO OSSC (ODOT/APWA) SPECIFICATIONS, CURRENT EDITION.
2. SEDIMENT BARRIERS SHALL BE MAINTAINED UNTIL UP-SLOPE AREA IS PERMANENTLY STABILIZED.
3. AT NO TIME SHALL SEDIMENT BE ALLOWED TO ACCUMULATE ABOVE THE TOP OF THE STRAW WATTLE.
4. NEW SEDIMENT BARRIERS SHALL BE INSTALLED UPHILL AS REQUIRED TO CONTROL SEDIMENT TRANSPORT.

LAST REVISION DATE: JUNE 2015	JO # STANDARD
<b>STRAW WATTLE SEDIMENT BARRIER</b>	
(NTS)	
NOSD, OR	DETAIL NO. 612

MAY BE USED SHORT TERM  
W/UTILITY WORK AND WITH  
PHASING OF DEVELOPMENT.

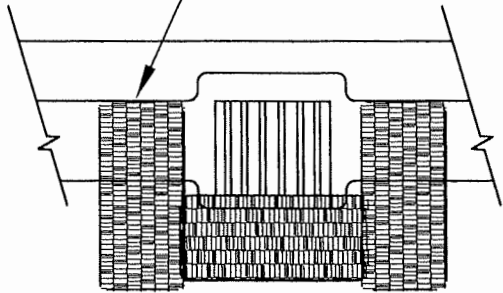

CURB INLET C.B.

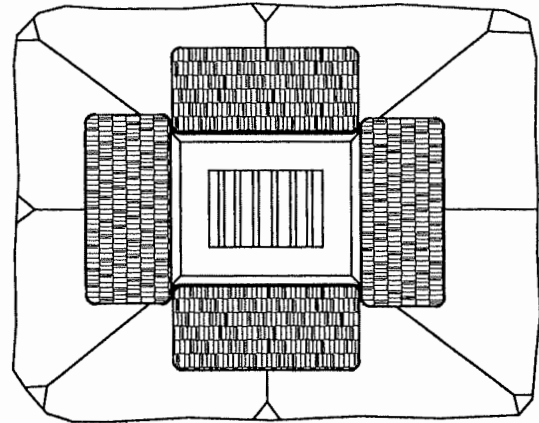

AREA DRAIN

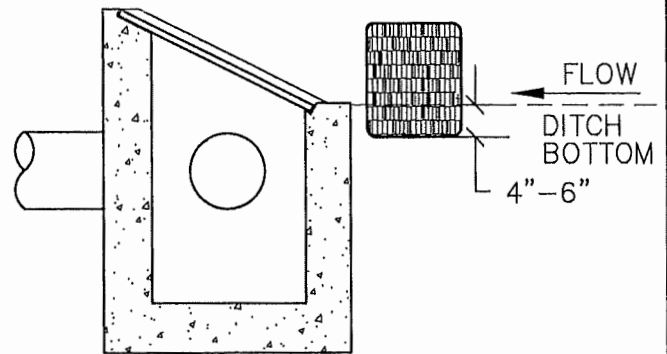
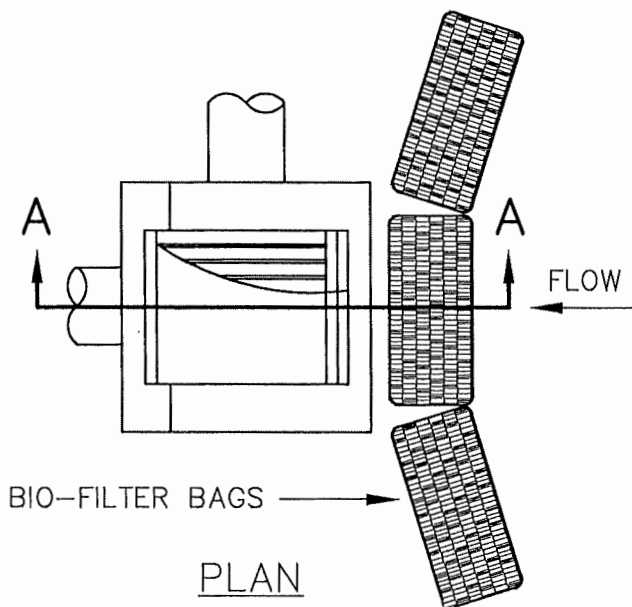

SECTION A-A

DITCH INLET C.B.

MAINTENANCE NOTES:

1. SEDIMENT BARRIERS SHALL BE MAINTAINED UNTIL UP-SLOPE AREA IS PERMANENTLY STABILIZED.
2. AT NO TIME SHALL MORE THAN ONE FOOT OF SEDIMENT BE ALLOWED TO ACCUMULATE BEHIND SEDIMENT FENCES OR BIOFILTER BAGS.
3. NEW SEDIMENT BARRIERS SHALL BE INSTALLED UPHILL AS REQUIRED TO CONTROL SEDIMENT TRANSPORT.

LAST REVISION DATE: APRIL 2014	JO # STANDARD
INLET SEDIMENT CONTROL	
(NTS)	
NOSD, OR	DETAIL NO. 613

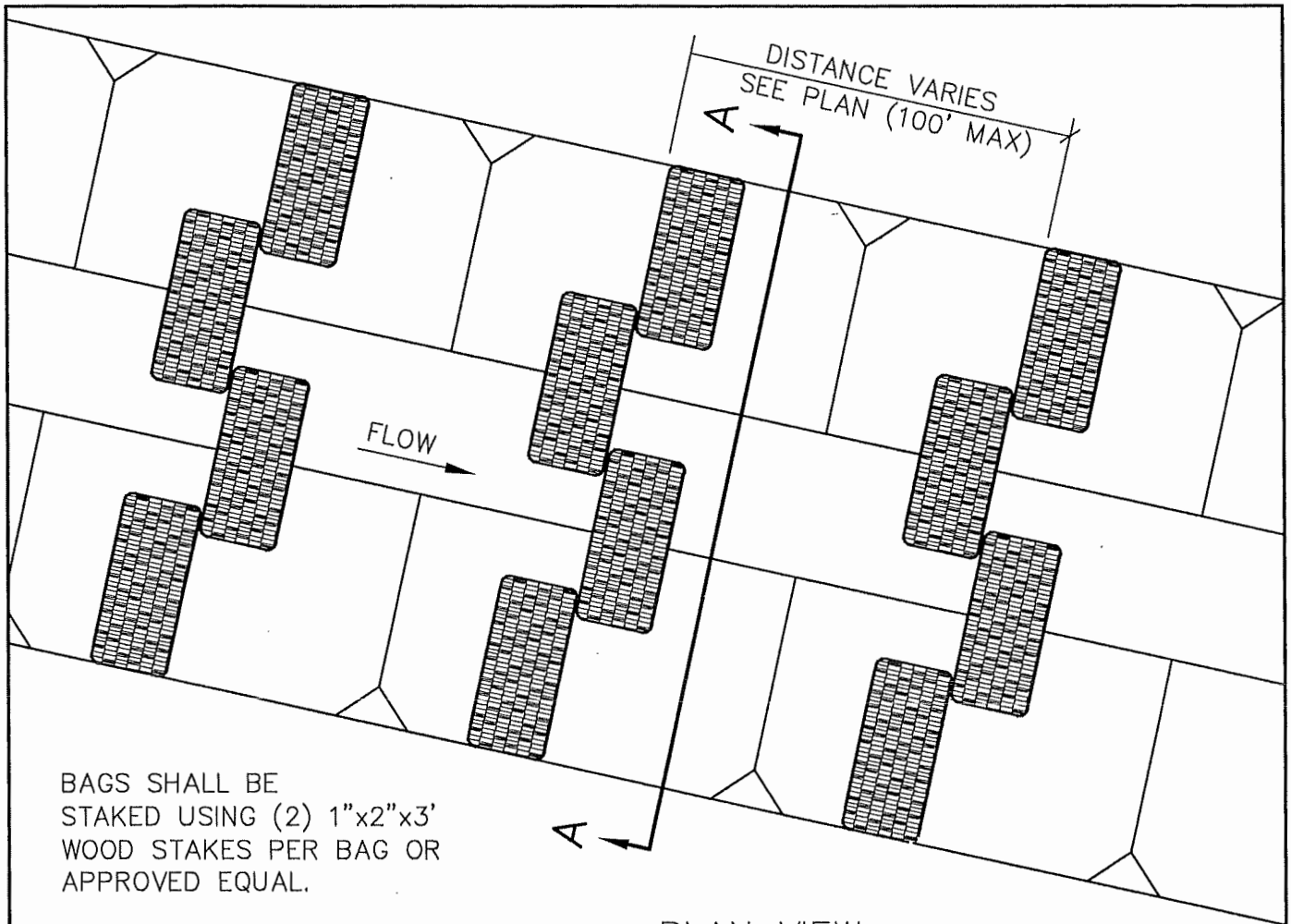

BAGS SHALL BE STAKED USING (2) 1"x2"x3' WOOD STAKES PER BAG OR APPROVED EQUAL.

PLAN VIEW

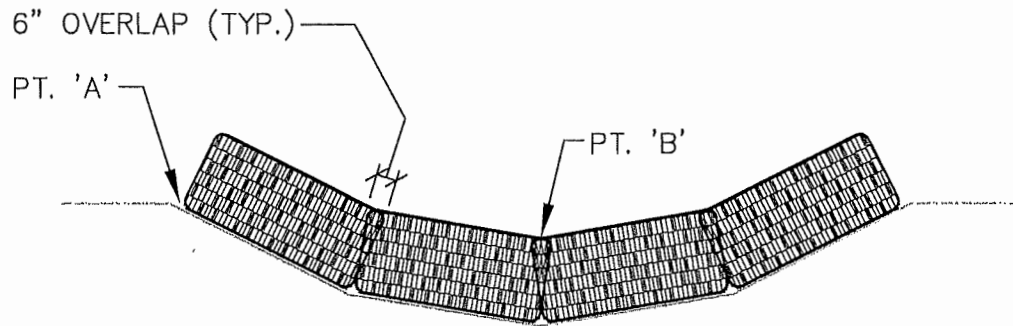

SECTION A-A

MAINTENANCE NOTES:

1. SEDIMENT BARRIERS SHALL BE MAINTAINED UNTIL UP-SLOPE AREA IS PERMANENTLY STABILIZED.
2. AT NO TIME SHALL MORE THAN ONE FOOT OF SEDIMENT BE ALLOWED TO ACCUMULATE BEHIND BIOFILTER BAGS.
3. NEW SEDIMENT BARRIERS SHALL BE INSTALLED UPHILL AS REQUIRED TO CONTROL SEDIMENT TRANSPORT.
4. PT. 'A' SHALL BE 6" MIN. HIGHER THAN PT. 'B'.

LAST REVISION DATE: APRIL 2014	JO # STANDARD
<b>DITCH AND SWALE EROSION PROTECTION</b>	
(NTS)	
NOSD, OR	DETAIL NO. 614

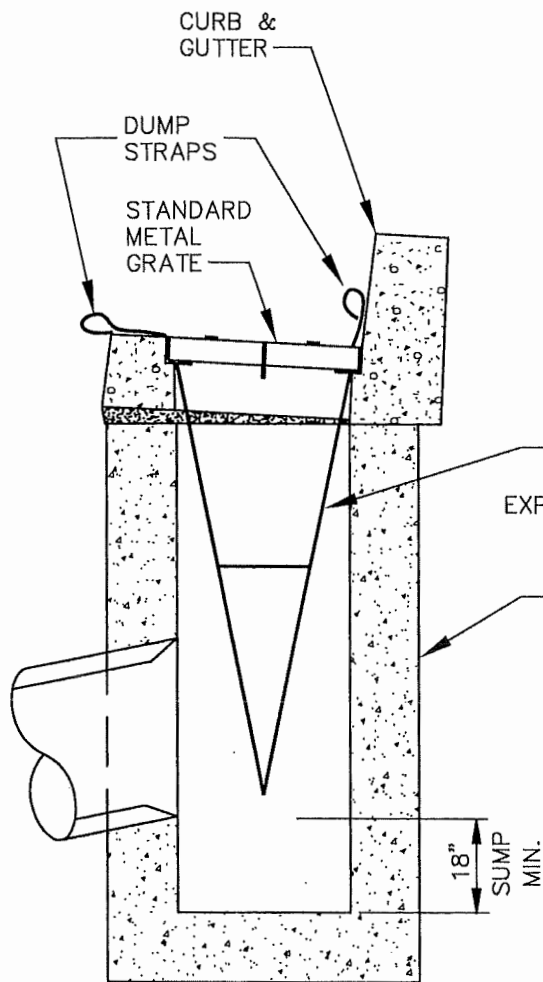

INSTALLATION DETAIL

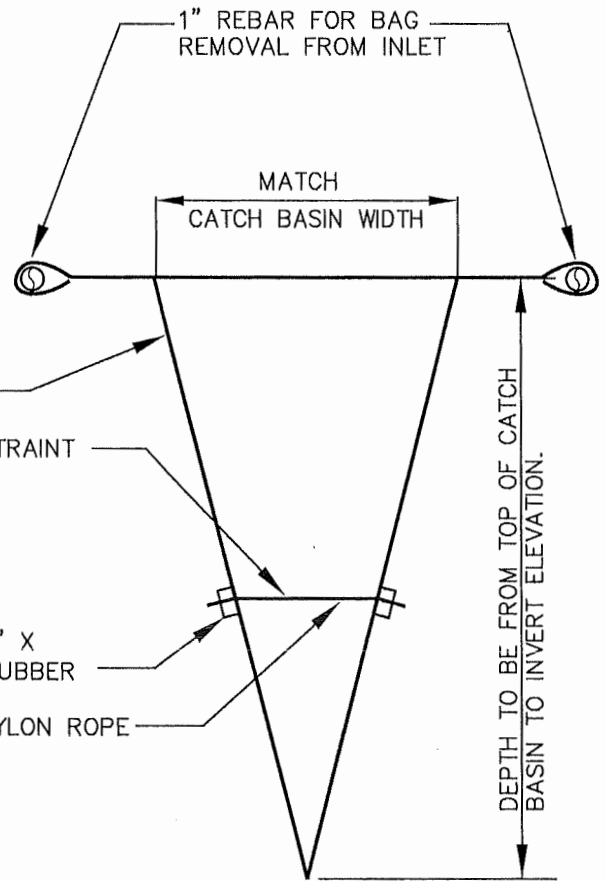

BAG DETAIL

NOTES:

1. EMPTY SILT SACK AS NECESSARY.
2. SILTSACK SEDIMENT CONTROL DEVICE AS MANUFACTURED BY ACF ENVIRONMENTAL AND SUPPLIED BY ACF WEST (503) 771-5115 OR APPROVED EQUAL.

LAST REVISION DATE: OCT 2006	
SILT SACK INLET DETAIL	
(NTS)	
NOSD, OR	DETAIL NO. 615

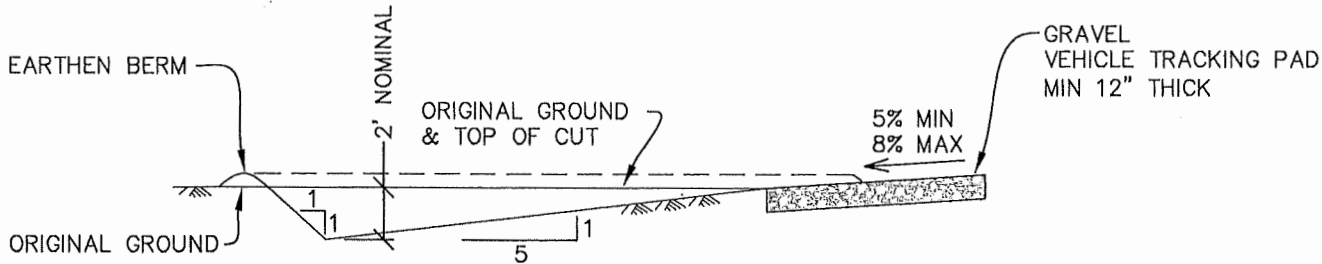

SECTION B-B

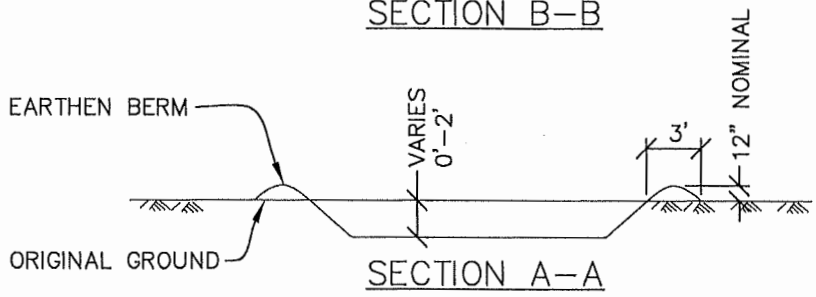

SECTION A-A

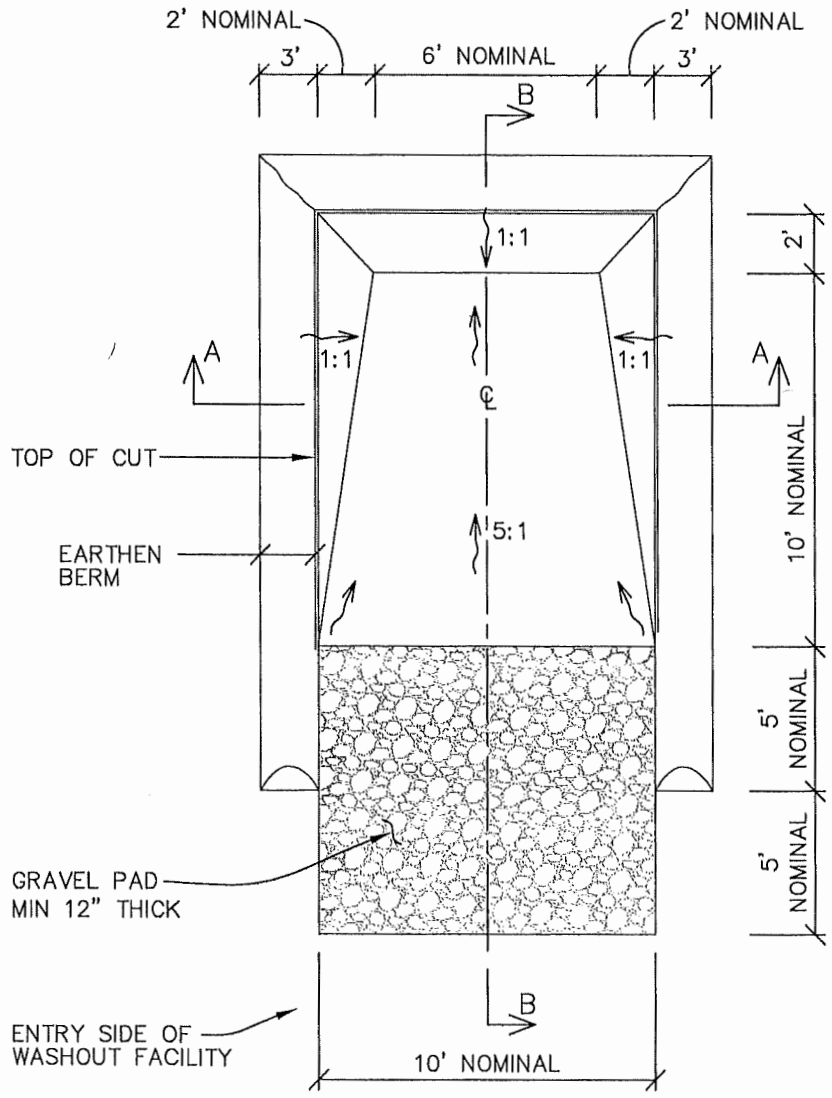

CONCRETE WASHOUT AREA PLAN  
N.T.S.

CWA INSTALLATION NOTES:

1. SEE DRAWINGS FOR CWA INSTALLATION LOCATION.
2. DO NOT LOCATE WASHOUT AREA WITHIN 200' OF ANY NATURAL DRAINAGE WAY.
3. THE CWA SHALL BE INSTALLED PRIOR TO CONCRETE PLACEMENT ON SITE.
4. VEHICLE TRACKING PAD SHALL BE SLOPED 5% TOWARDS THE CWA.

CWA MAINTENANCE NOTES:

1. INSPECT BMP'S EACH WORKDAY, AND MAINTAIN THEM IN EFFECTIVE OPERATING CONDITION.
2. THE CWA SHALL BE REPAIRED, CLEANED, OR ENLARGED AS NECESSARY TO MAINTAIN CAPACITY FOR CONCRETE WASTE. CONCRETE MATERIALS ACCUMULATED IN PIT SHALL BE REMOVED ONCE THE MATERIALS HAVE REACHED A DEPTH OF 18".
3. CONCRETE WASHOUT WATER, WASTED PIECES OF CONCRETE, AND ALL OTHER DEBRIS IN THE PIT SHALL BE REMOVED FROM THE JOB SITE.
4. THE CWA SHALL REMAIN IN PLACE UNTIL ALL CONCRETE FOR THE PROJECT IS PLACED.
5. WHEN THE CWA IS REMOVED, COVER THE DISTURBED AREA WITH TOP SOIL. SEED AND MULCH OR OTHERWISE STABILIZED IN A MANNER APPROVED BY THE LOCAL JURISDICTION.

LAST REVISION DATE: NOV 2018	JO # STANDARD
<b>TEMPORARY CONCRETE WASHOUT AREA (CWA)</b> (NTS)	
NOSD, OR	DETAIL NO. 616

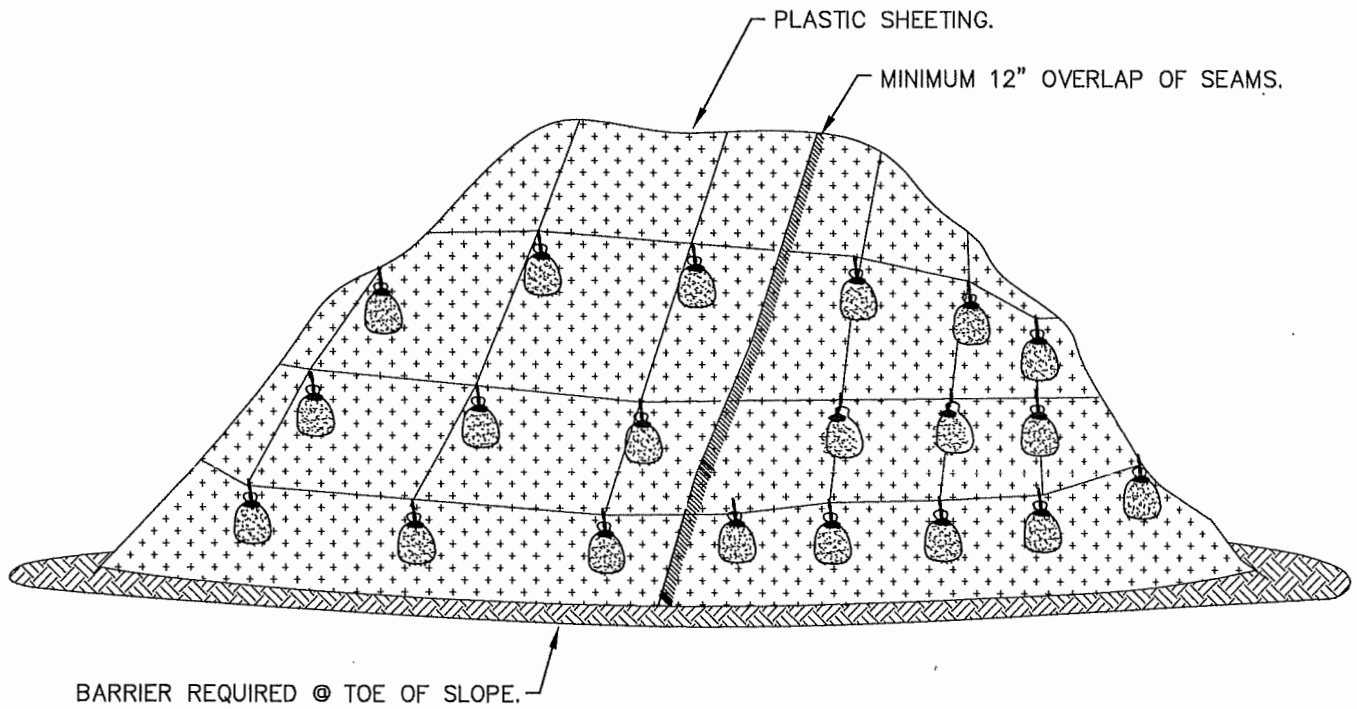

## STOCKPILE DETAIL

### NOTES:

1. MINIMUM 12" OVERLAP OF ALL SEAMS REQUIRED.
2. SEDIMENT BARRIER REQUIRED @ TOE OF STOCK PILE.
3. COVERING MAINTAINED TIGHTLY IN PLACE BY USING SANDBAGS OR TIRES ON ROPES WITH A MAXIMUM 10' GRID SPACING IN ALL DIRECTIONS.
4. PLASTIC SHEETING TO EXTEND A MINIMUM OF 12" PAST THE BOTTOM OF THE PILE ONTO SURROUNDING GRADE ON ALL SIDES.

LAST REVISION DATE: JAN 2019	JO # STANDARD
<b>STOCKPILE COVER DETAIL</b> (NTS)	
NOSD, OR	DETAIL NO. <b>617</b>